

HOME SOURCE®

ASSEMBLY INSTRUCTION

MODEL:JZ88 MOP

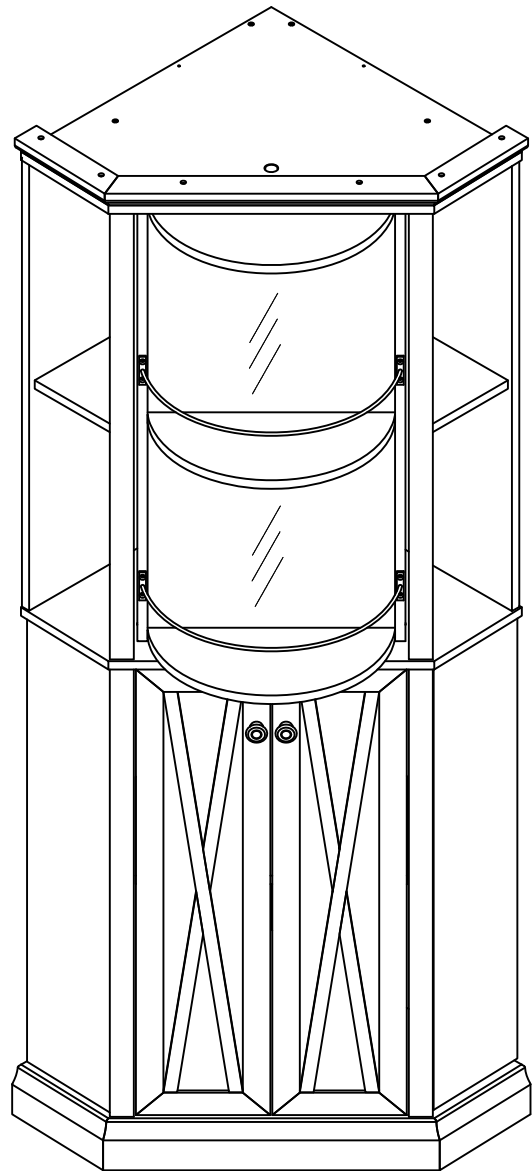
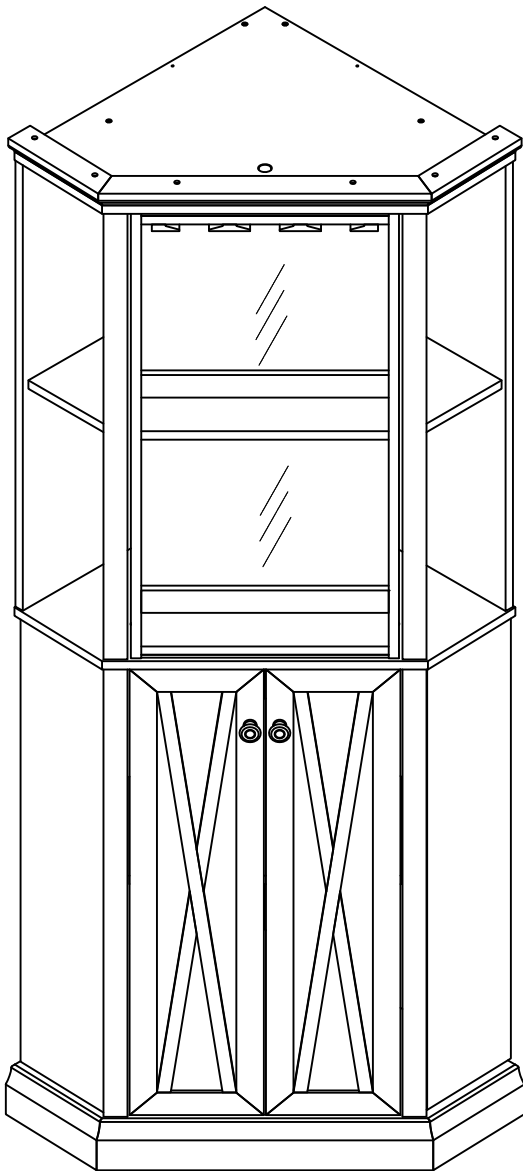

GENERAL ASSEMBLY INSTRUCTIONS

A few Tips before starting to assemble your new bookshelf, table, chair, or any other item

- I. Before you can begin assembling your piece of furniture, make sure that there are no parts or hardware missing.
- II. Make sure you pay careful attention to each step before you progress onto the next step. This way you will be able to assemble your item effectively and speedily.
- III. If you have help available, two people, or more are recommended to assist you to assemble the product. This ensures that it takes less time and less effort.
- IV. In the contents of the packaging, you will find pieces of Wood and individual dowels, screws, and bolts. These are the four main types of hardware that are required to assemble your item.
- V. Glue is included to ensure the wood dowels are secured effectively. Before you start inserting a dowel in place, make sure you find the right hole.
- VI. To insert securely, place a minimal amount of glue at the end of the dowel before you start attaching separate pieces of hardware.
- VII. A Philips head screw driver is a prerequisite to successfully assemble this product.
- VIII. Besides a power drill, power tools are not necessary to put this product together.
- IX. A drill may be needed to ensure that the product is efficiently secured to a wall.

Some products may come with three-way hidden hinges.

- a) These hidden three-way hinges can be fastened in place horizontally by mounting a screw.

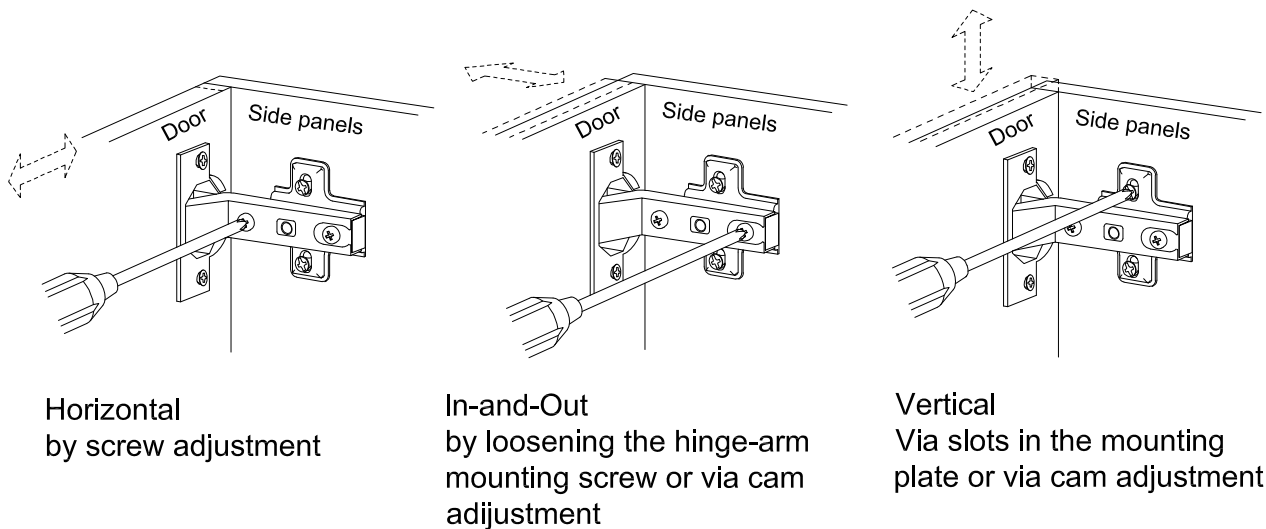

- b) They can be secured inward and outward by freeing the hinge arm, or vertically.
c) This is done through gentle adjustment or slotting the hinges into the mounting plate.

INSTRUCCIONES GENERALES PARA ENSAMBLE

Algunos consejos antes de comenzar a armar su nueva estantería, mesa, silla o cualquier otro artículo

- I. Antes de que pueda comenzar a ensamblar su mueble, asegúrese de que no falten piezas o hardware.
- II. Asegúrese de prestar mucha atención a cada paso antes de avanzar al siguiente paso. De esta manera, podrá ensamblar su artículo de manera efectiva y rápida.
- III. Si tiene ayuda disponible, se recomiendan dos personas o más para ayudarlo a ensamblar el producto. Esto asegura que tome menos tiempo y menos esfuerzo.
- IV. En el contenido del embalaje, encontrará piezas de madera y clavijas, tornillos y pernos (Tarugos) individuales. Estos son los cuatro tipos principales herramientas que se requieren para ensamblar su artículo.
- V. Se incluye pegamento para garantizar que las clavijas de madera se aseguren de manera efectiva. Antes de comenzar a insertar una clavija en su lugar, asegúrese de encontrar el orificio correcto.
- VI. Para insertar de forma segura, coloque una cantidad mínima de pegamento al final de la clavija antes de comenzar a colocar piezas separadas de hardware.
- VII. Un destornillador de cabeza Philips. (Tornillos de tria) es un requisito previo para ensamblar con éxito este producto.
- VIII. Además de un taladro eléctrico, no son necesarias herramientas eléctricas para armar este producto.
- IX. Es posible que se necesite un taladro para garantizar que el producto se asegure de manera eficiente a una pared.

Algunos productos pueden venir con bisagras ocultas de tres vías.

- a) Estas bisagras ocultas de tres vías se pueden sujetar en su lugar horizontalmente montando un tornillo.

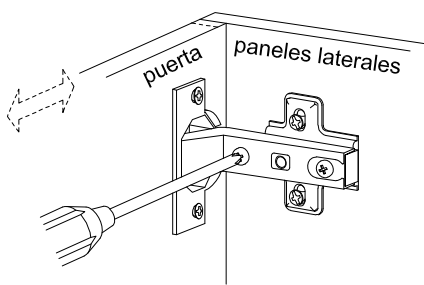

Horizontal
mediante el ajuste del tornillo

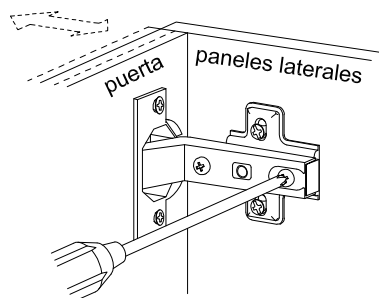

Hacia adentro o afuera
al aflojar el brazo de la bisagra
tornillo de montaje o mediante
ajuste de la leva

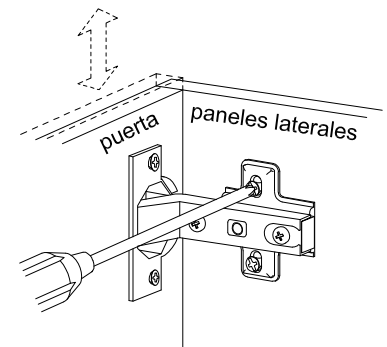







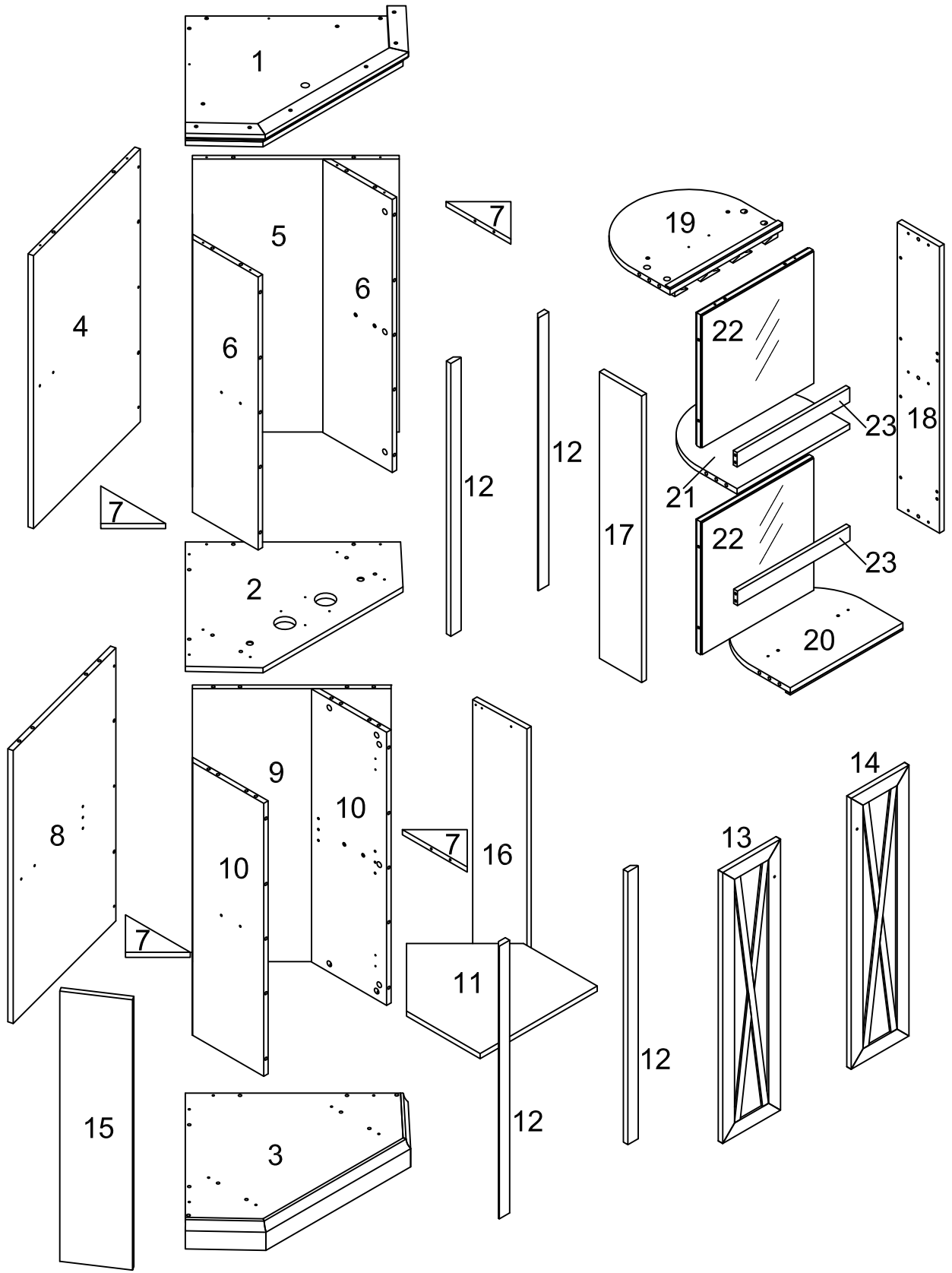





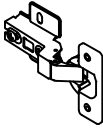

Vertical
por medio de ranuras en la
placa de montaje o mediante
el ajuste de la leva

- b) Se pueden asegurar hacia adentro y hacia afuera liberando el brazo de la bisagra, o verticalmente.
- c) Esto se hace a través de un ajuste suave o ranurando las bisagras en la placa de montaje.















Parts List

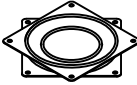

Hardware List

A		Ø5*25mm	Cam bolt	40 pcs
B		Ø15*11mm	Cam lock	40 pcs
C		Ø8*30mm	Wood Dowel	50 pcs
D		Ø6*30mm	Wood Dowel	20 pcs
E		Ø5*16mm	Shelf support pin	6 pcs
F		Ø26mm	Hinge	4 pcs
G		Ø4*15mm	Screw	16 pcs
H		Ø5/40*17*16mm	Door pivot	2 pcs
I		Ø5/40*17*16mm	Door pivot	2 pcs
J		Ø8.7mm	Glue oug	4 pcs
K		Ø3*15mm	Screw	8 pcs
L		Ø3.5*15mm	Screw	8 pcs
M		47*29*18.5mm	Bouncer	2 pcs
N		Ø3.5*15mm	Screw	10 pcs
O		30*22*1mm	iron	4 pcs

Hardware List

P		Ø3*12mm	Screw	4 pcs
Q		71*15*12.5mm	The magnet	1 pc
R		385*165*50mm	Rail	2 pcs
S		Ø4*45mm	Screw	42 pcs
T		Ø31*25mm	Handle	2 pcs
U		5/32*22mm	Handle Bolt	2 pcs
V		94*94*9mm	Rotary table	1 pc
W		80*20*23mm	Shaft	1 pc
X		Ø4*12mm	Screw	8 pcs
Y		Ø4*15mm	Screw	2 pcs
Z		Ø13*10mm	Screw	2 pcs
AA			Glue tube	1 pc
AB		Ø25mm	Sticker	30 pcs
AC			Anti-Tipping Kit	2 sets

Step 1

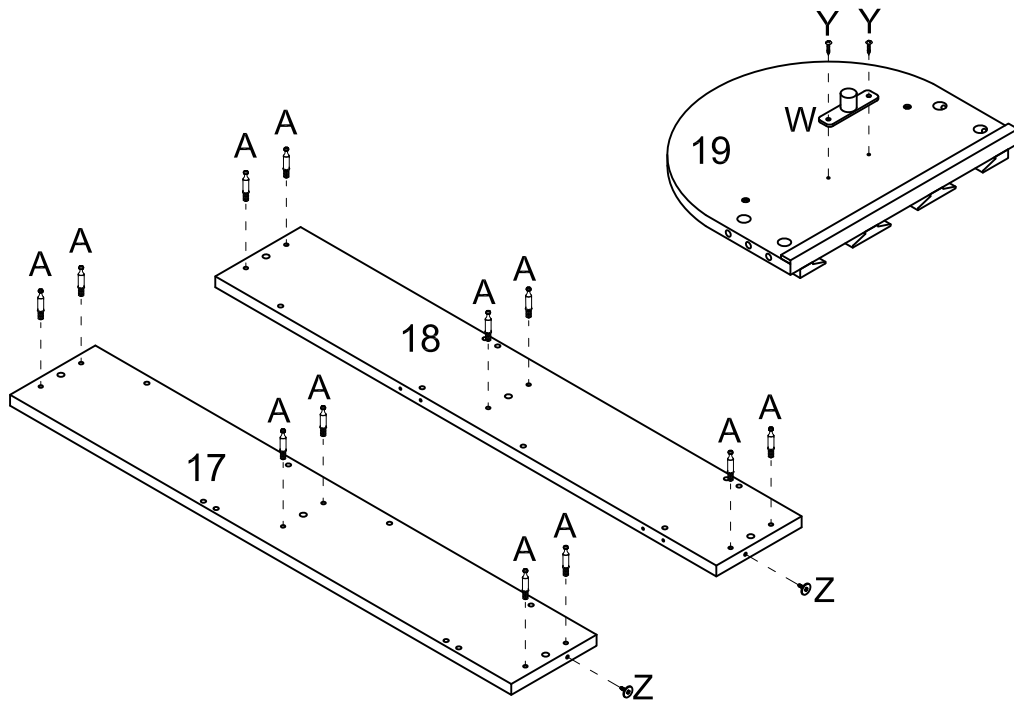

Step 2

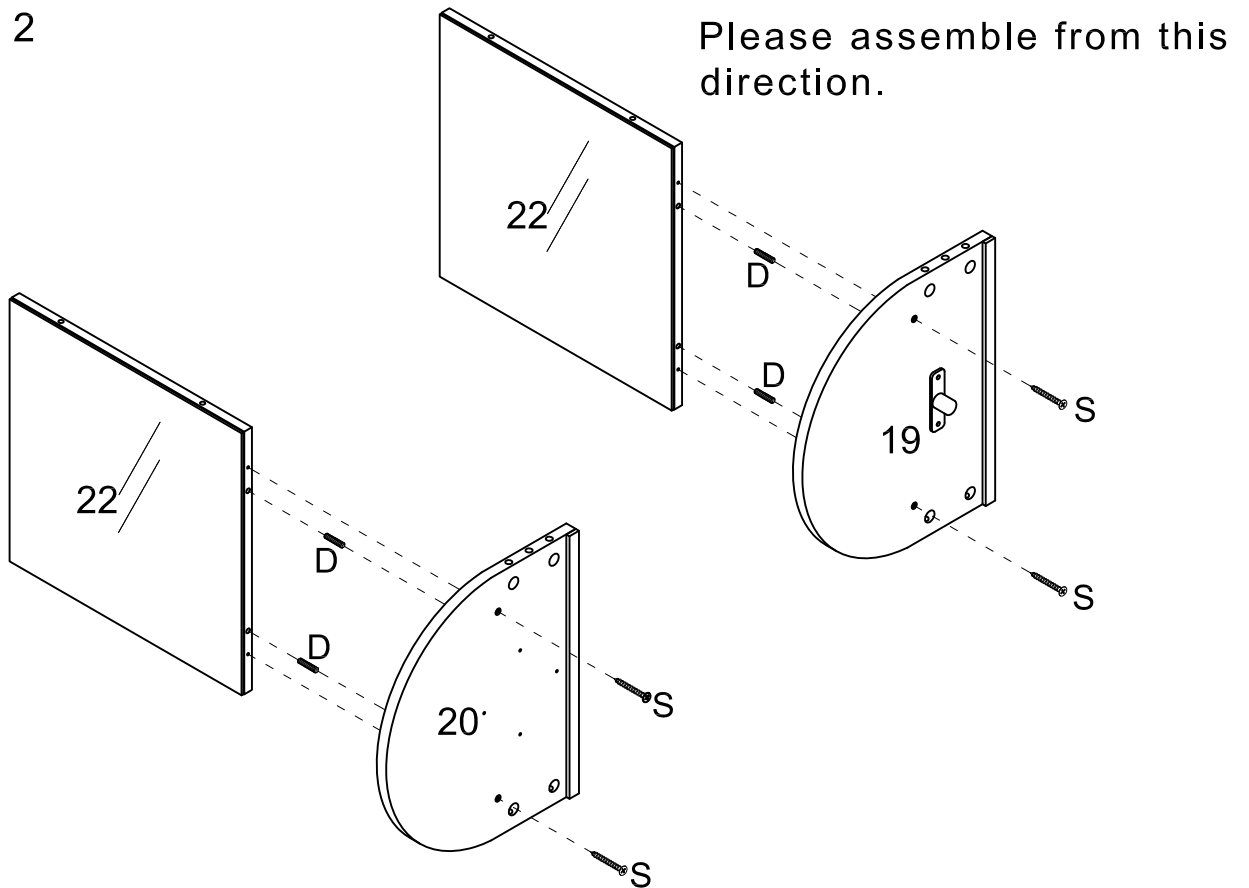

Step 3

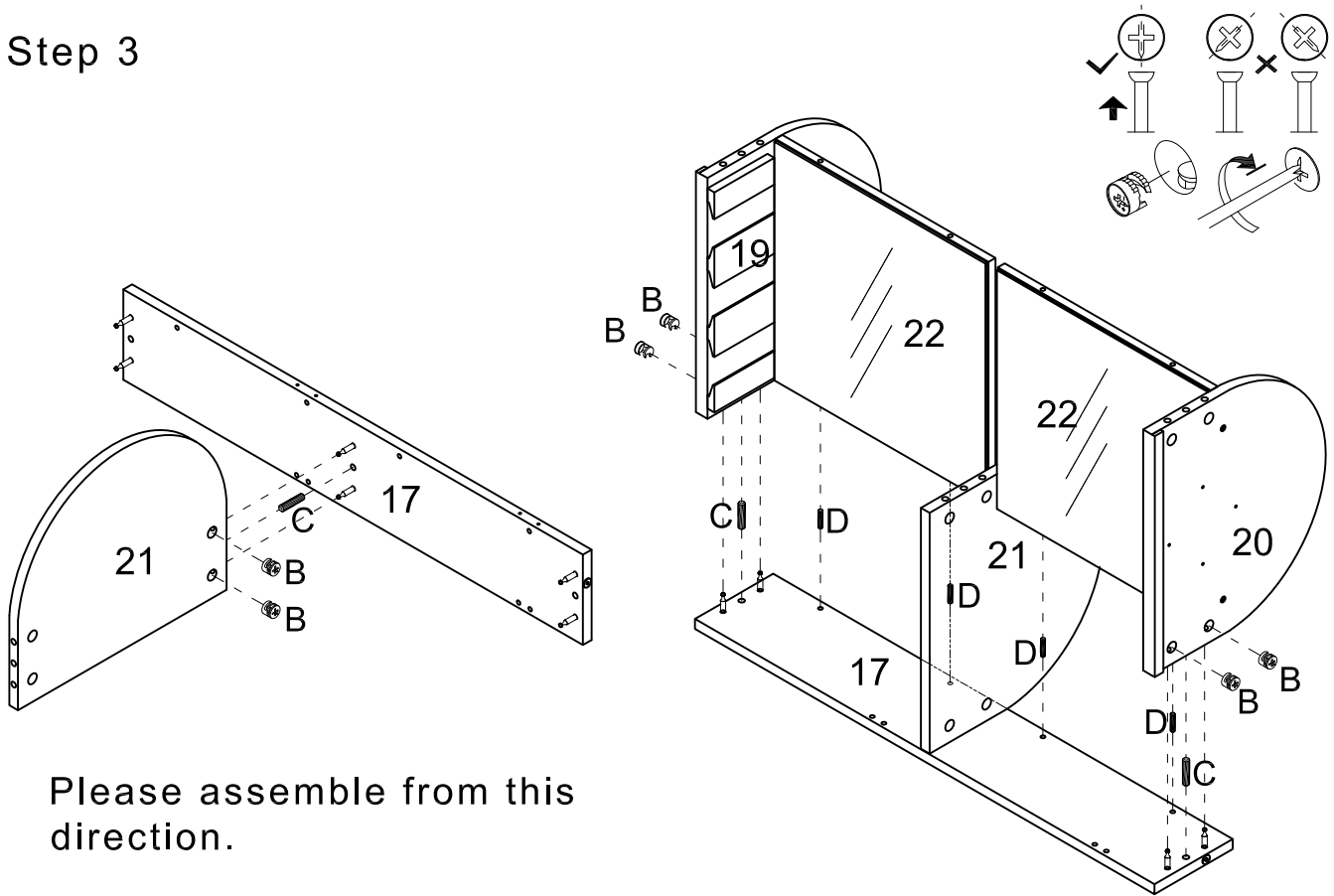

Please assemble from this direction.

Step 4

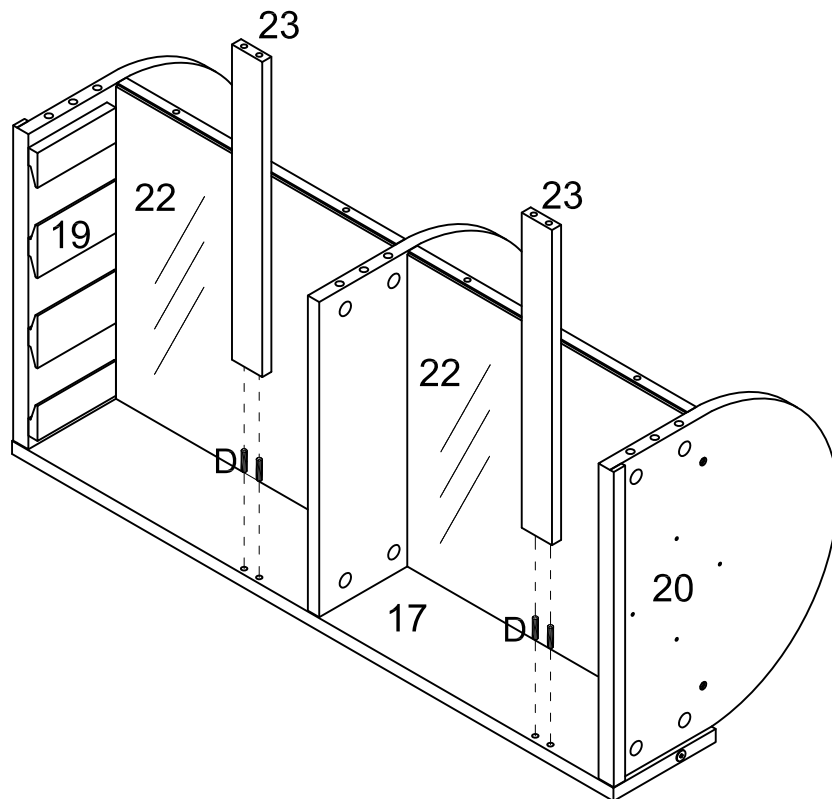

Step 5

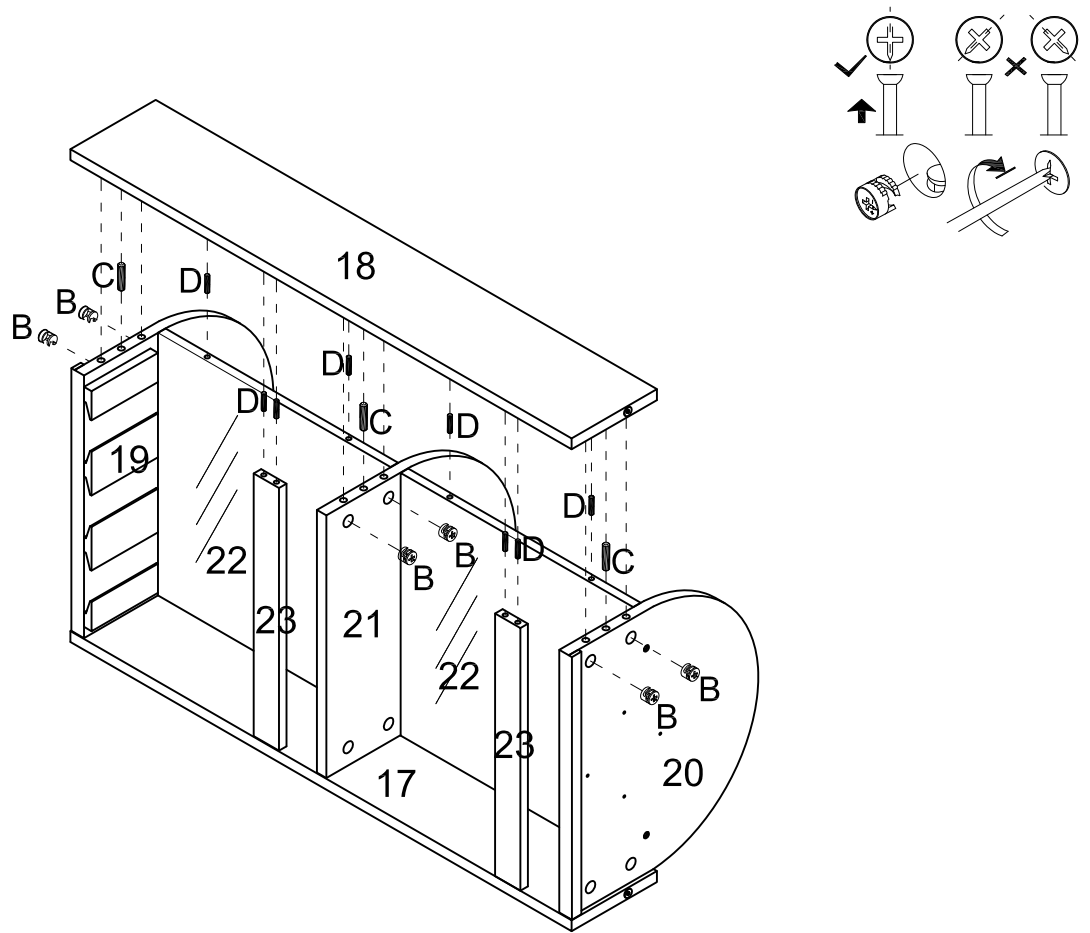

Step 6

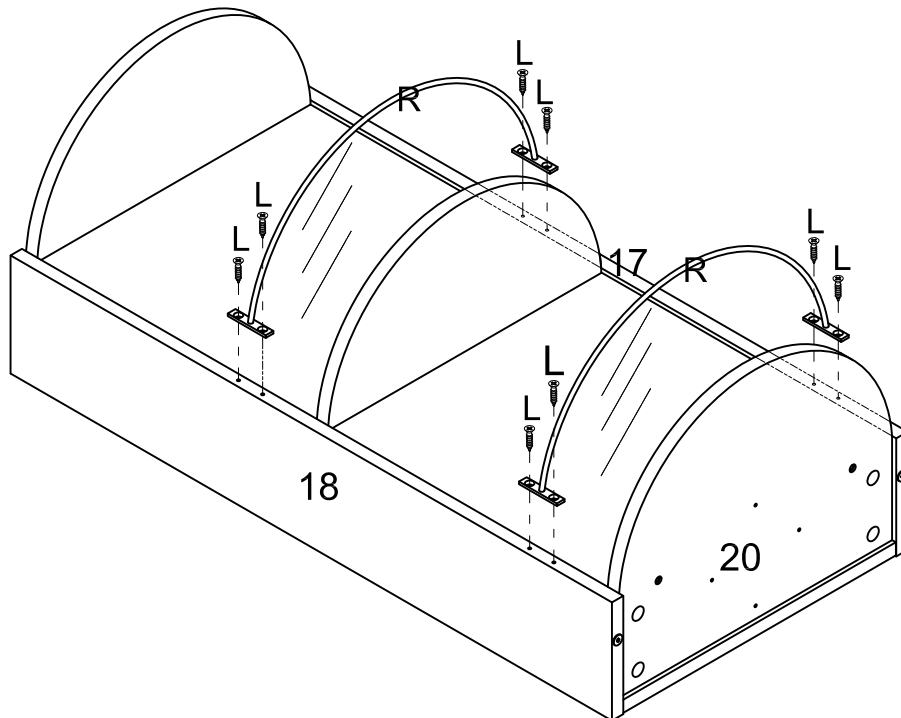

Step 7

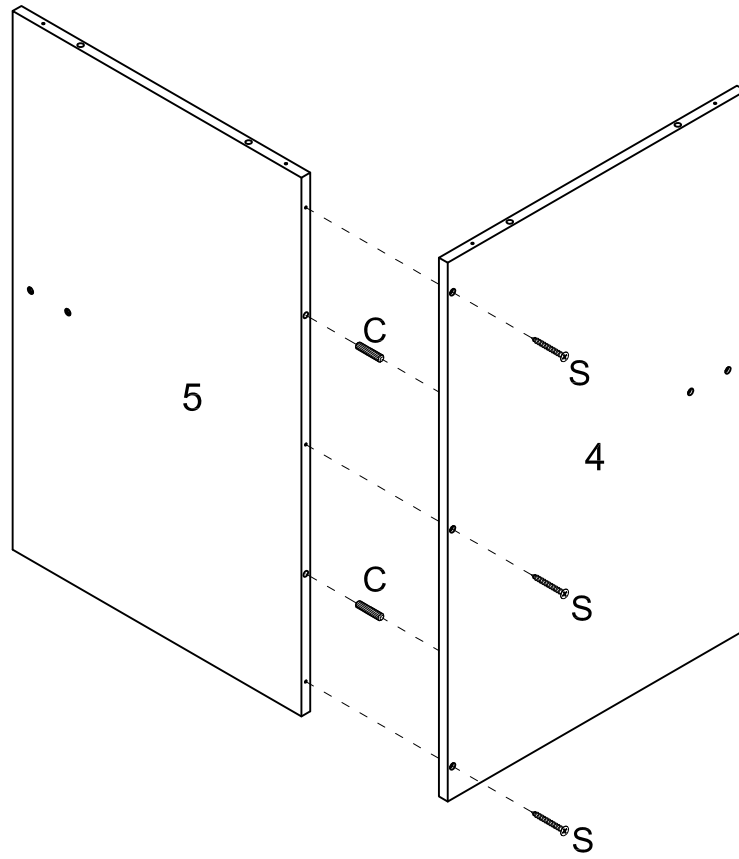

Step 8

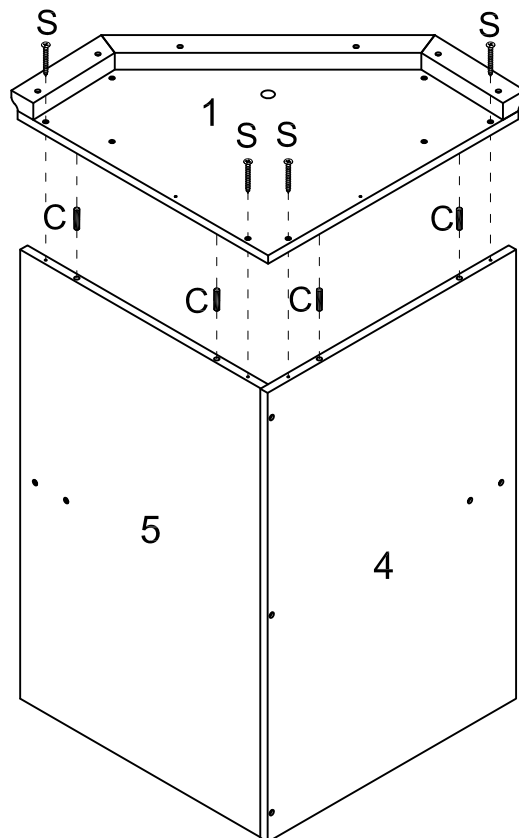

Step 9

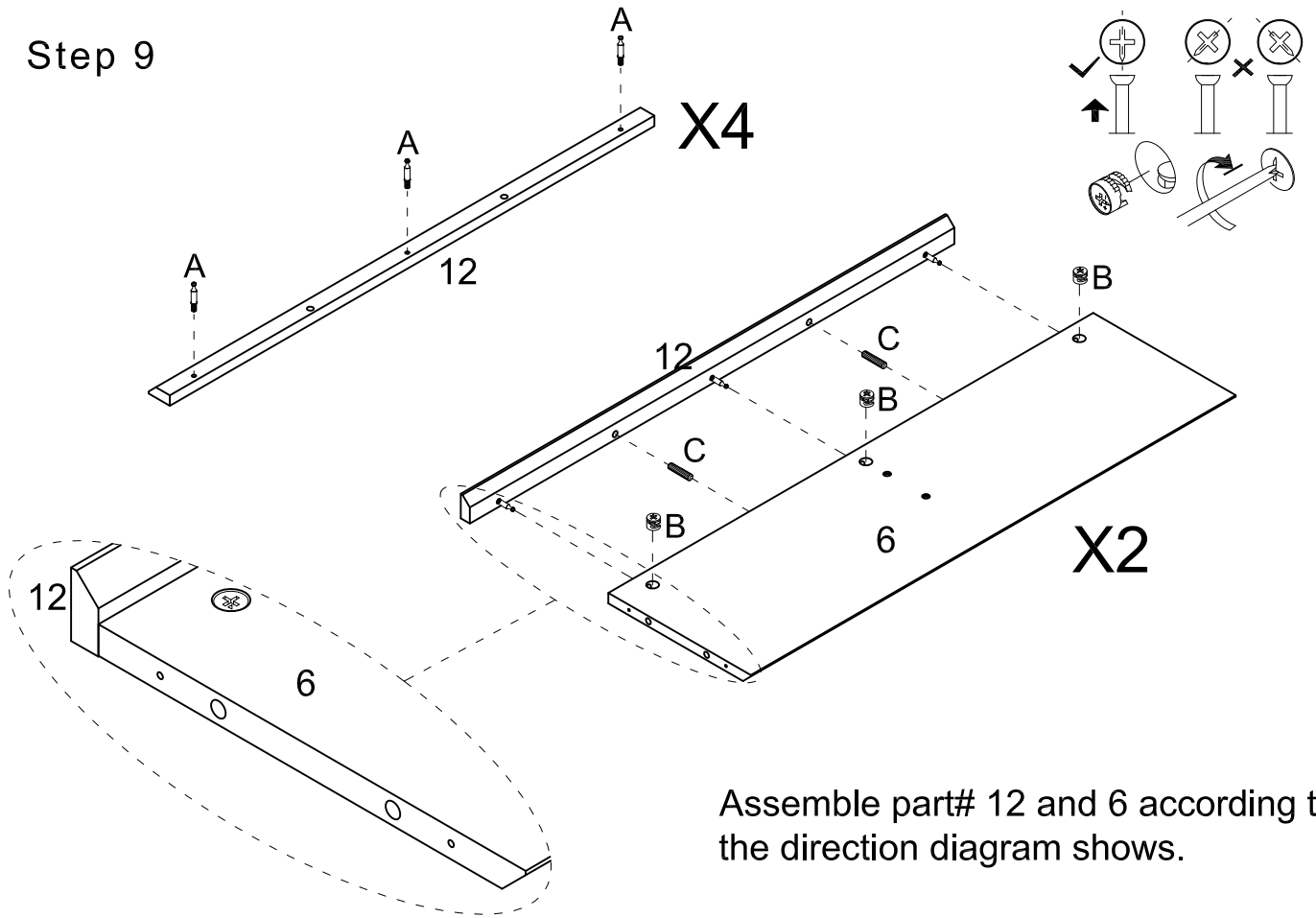

Step 10

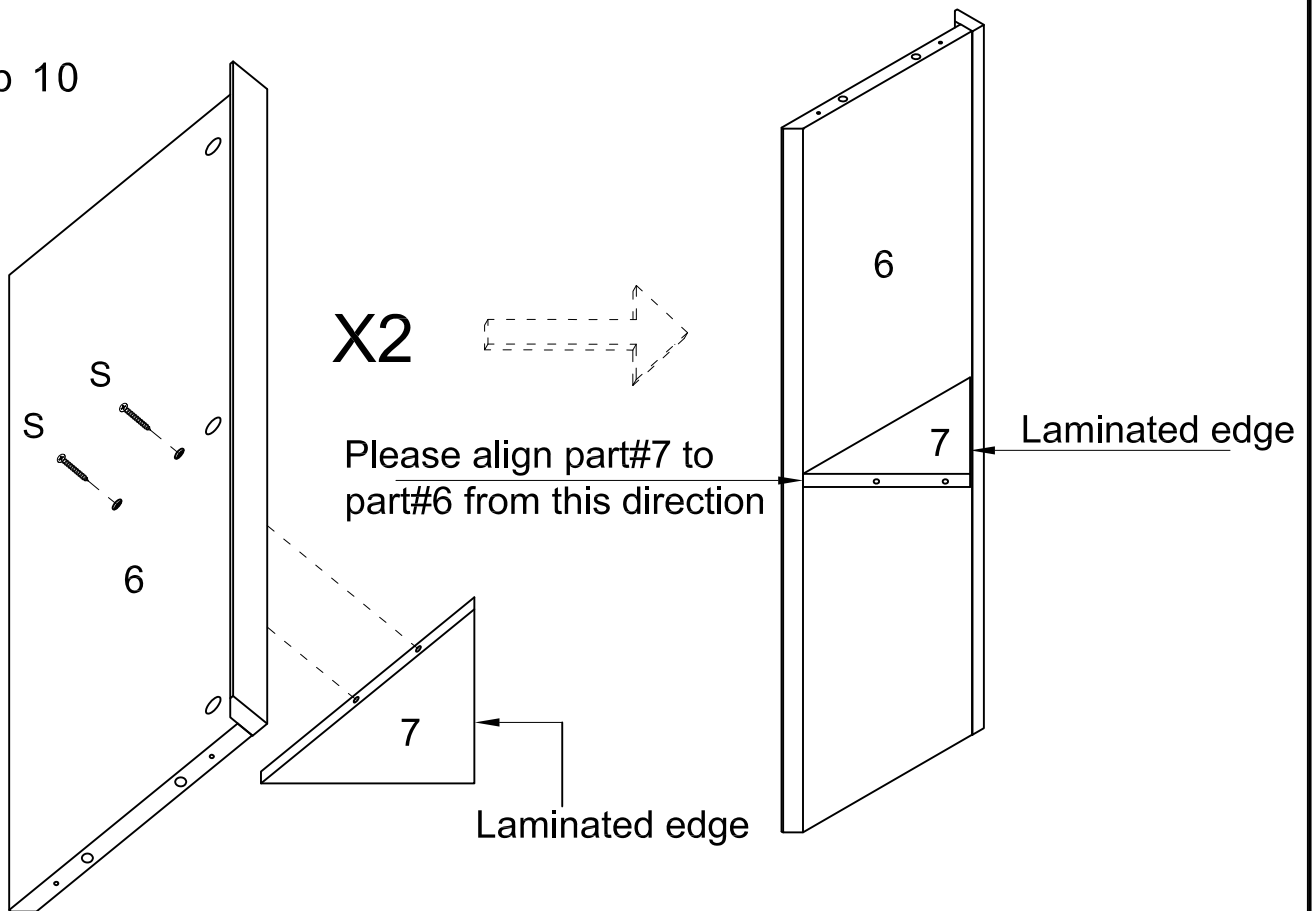

Step 11

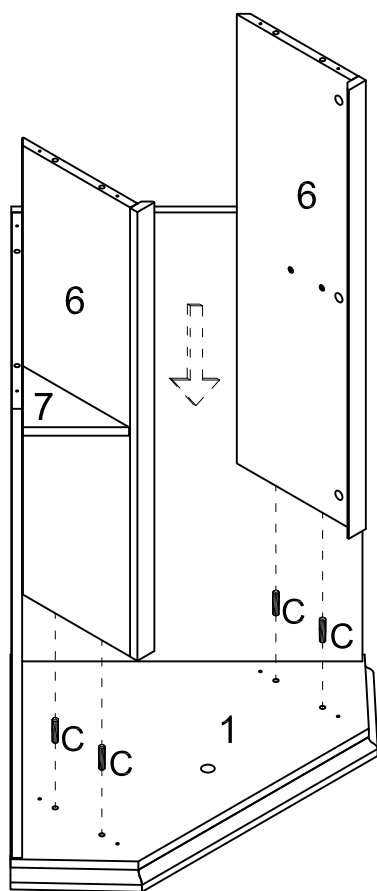

Step 12

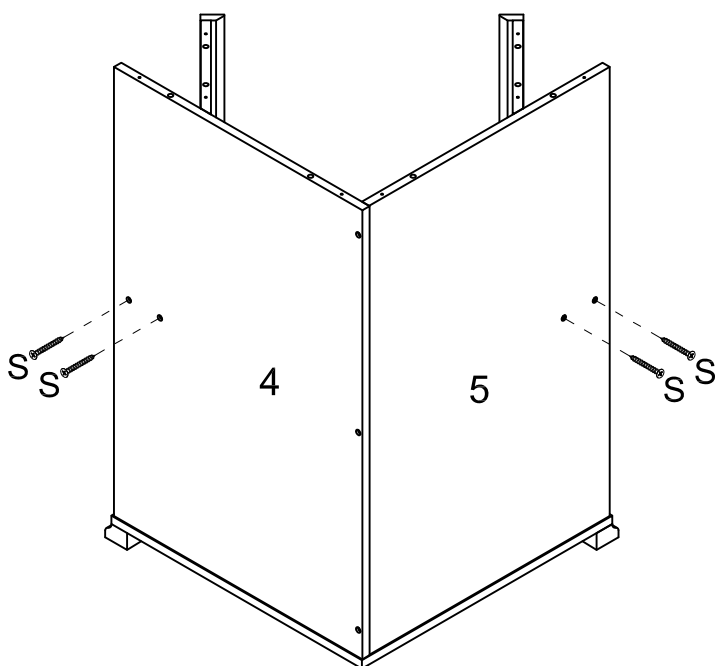

Step 13

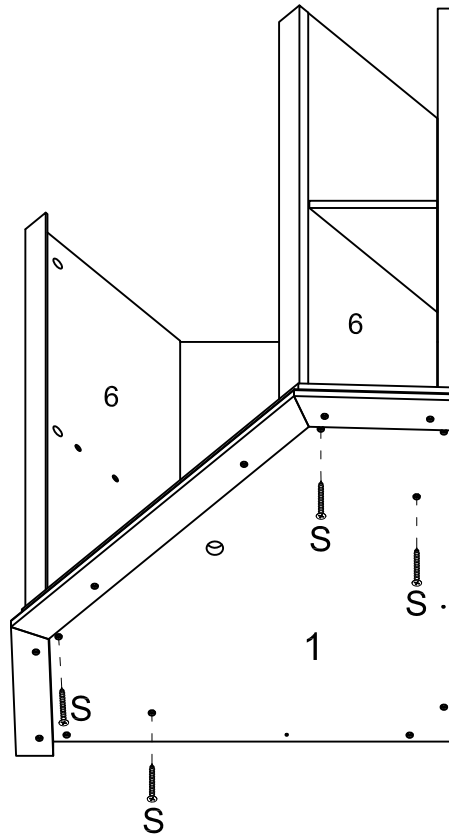

Step 14

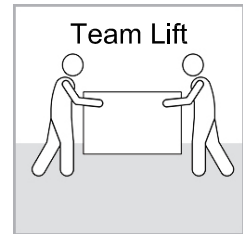
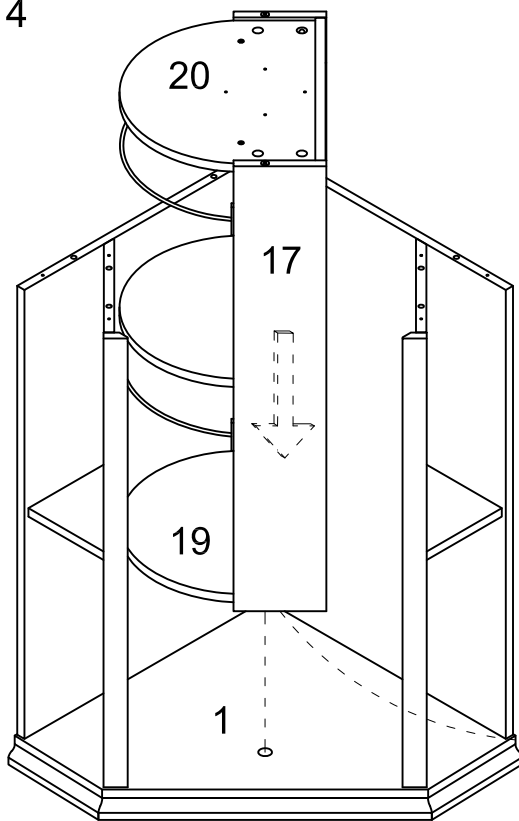

Make sure you have at least two people to put the top onto the base.

Step 15

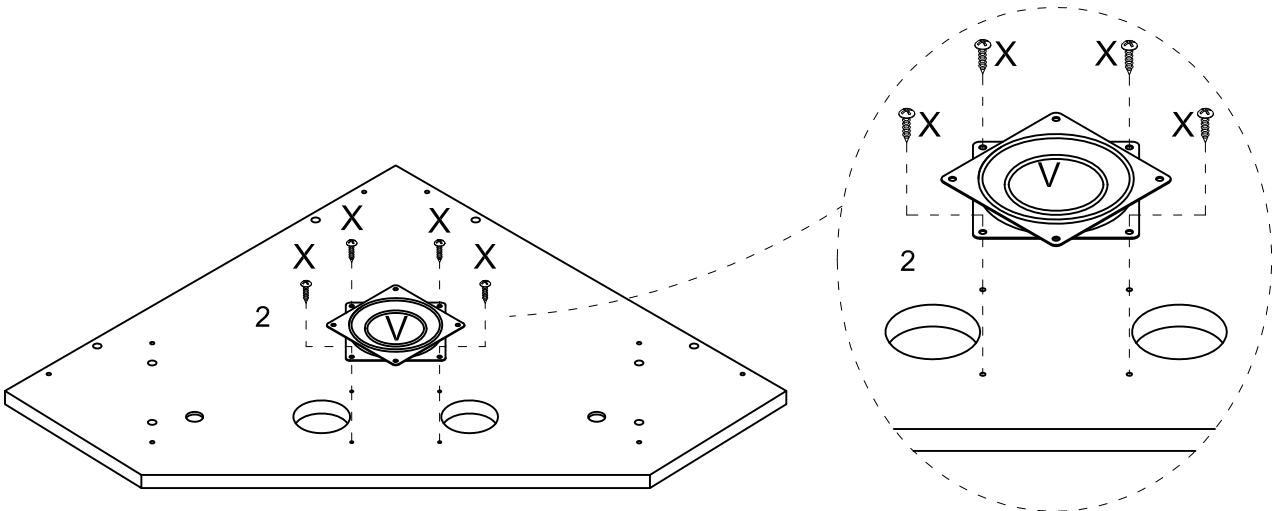

Please turn this turntable to this direction.

Step 16

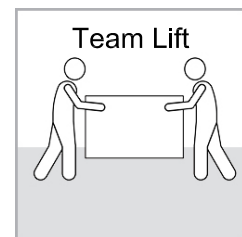
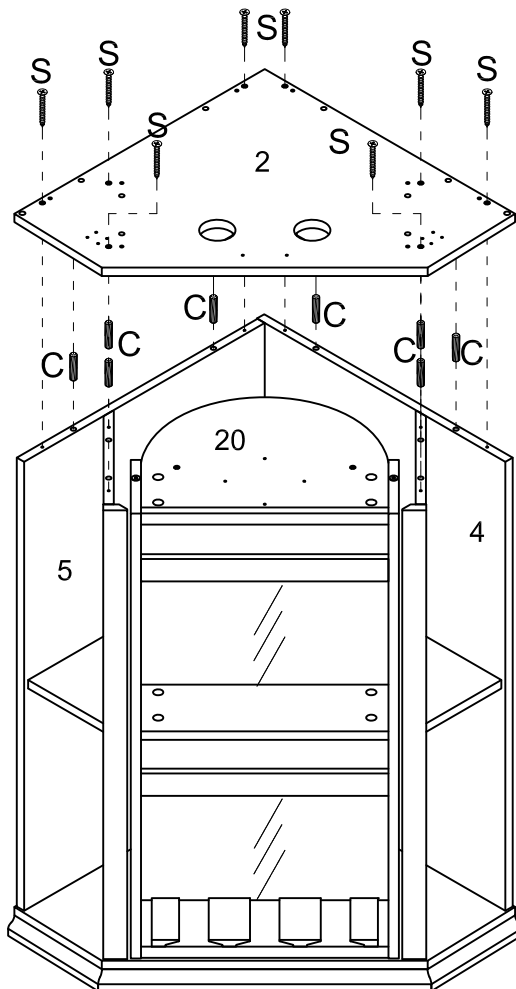

Make sure you have at least two people to put the top onto the base.

Step 17

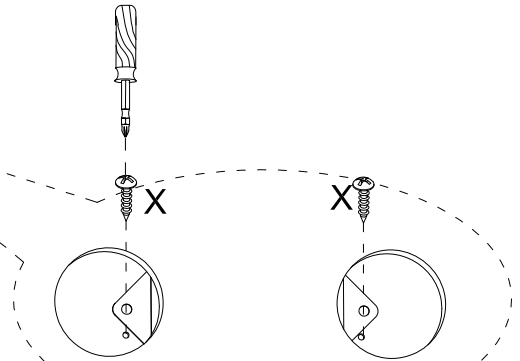
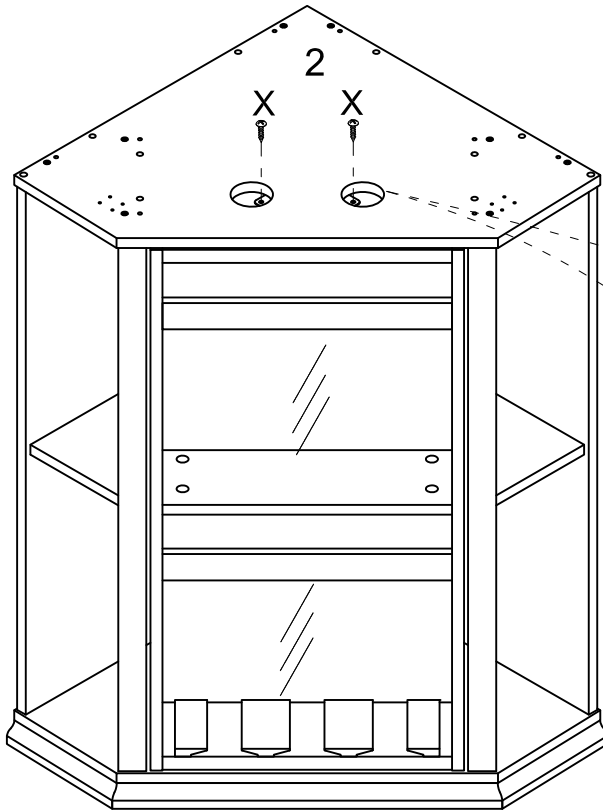

Secure four screws from this direction.

Step 18

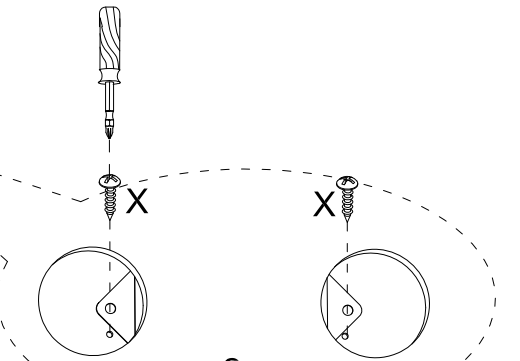
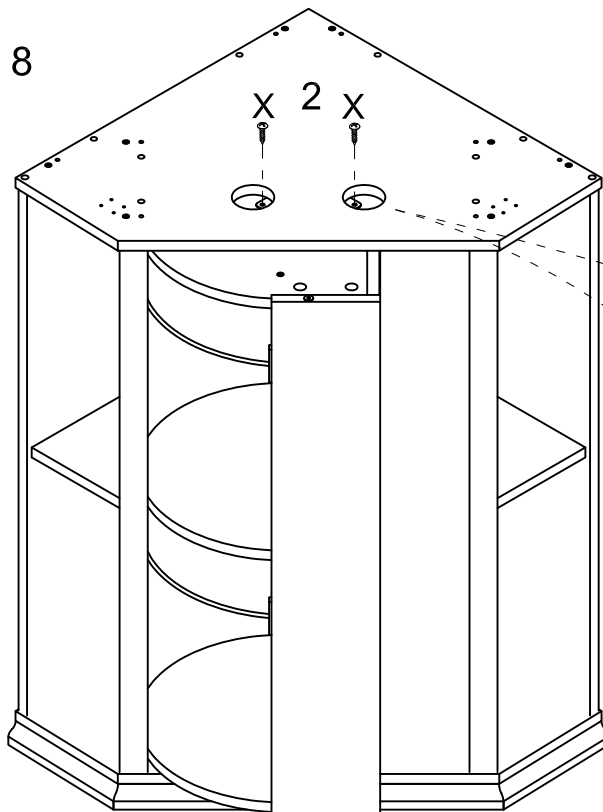

Secure another four screws from this other direction.

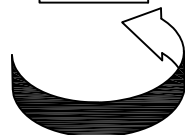

Rotate the middle part by 90 degree to assemble.

Step 19

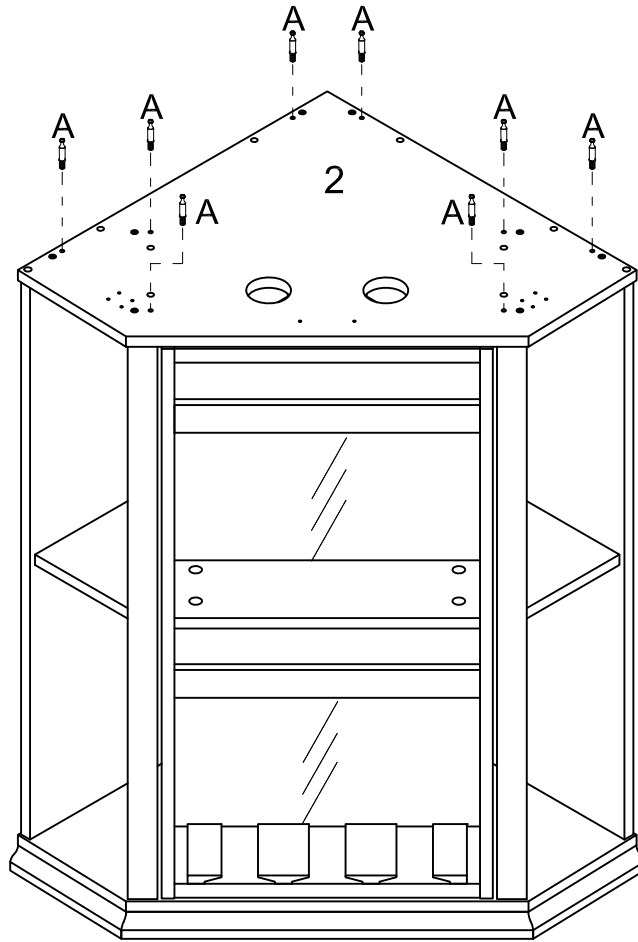

Step 20

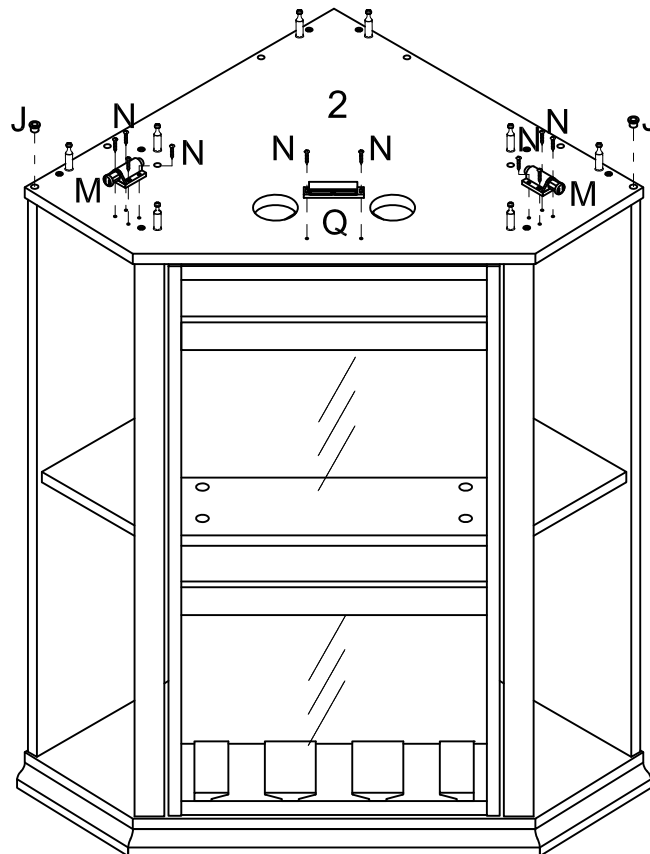

Step 21

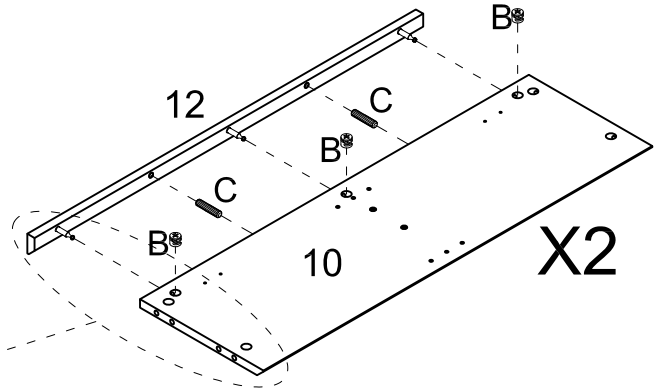
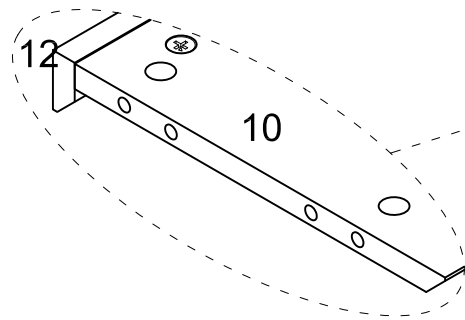
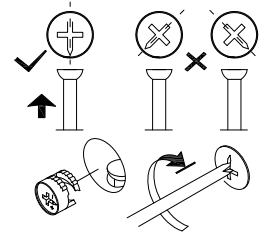
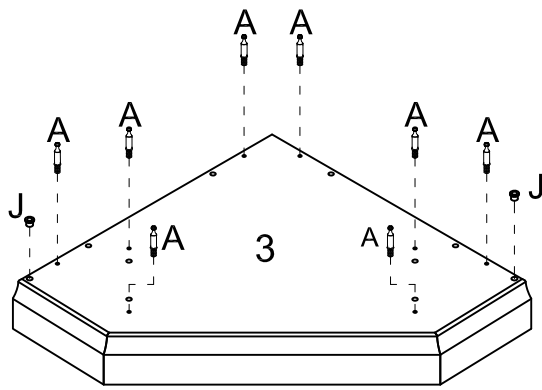

Assemble part# 12 and 10 according to the direction diagram shows.

Step 22

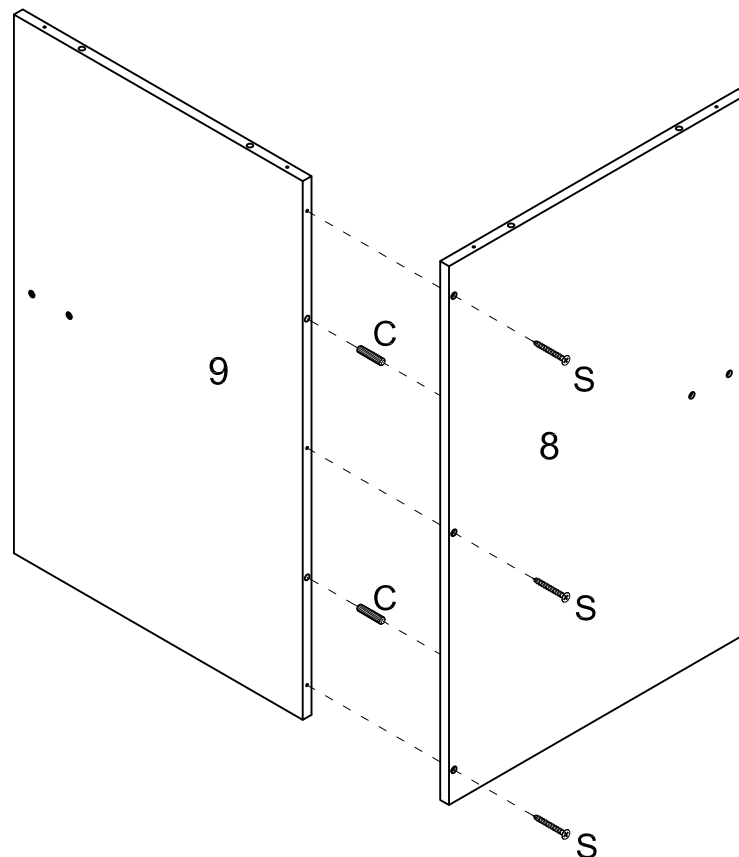

Step 23

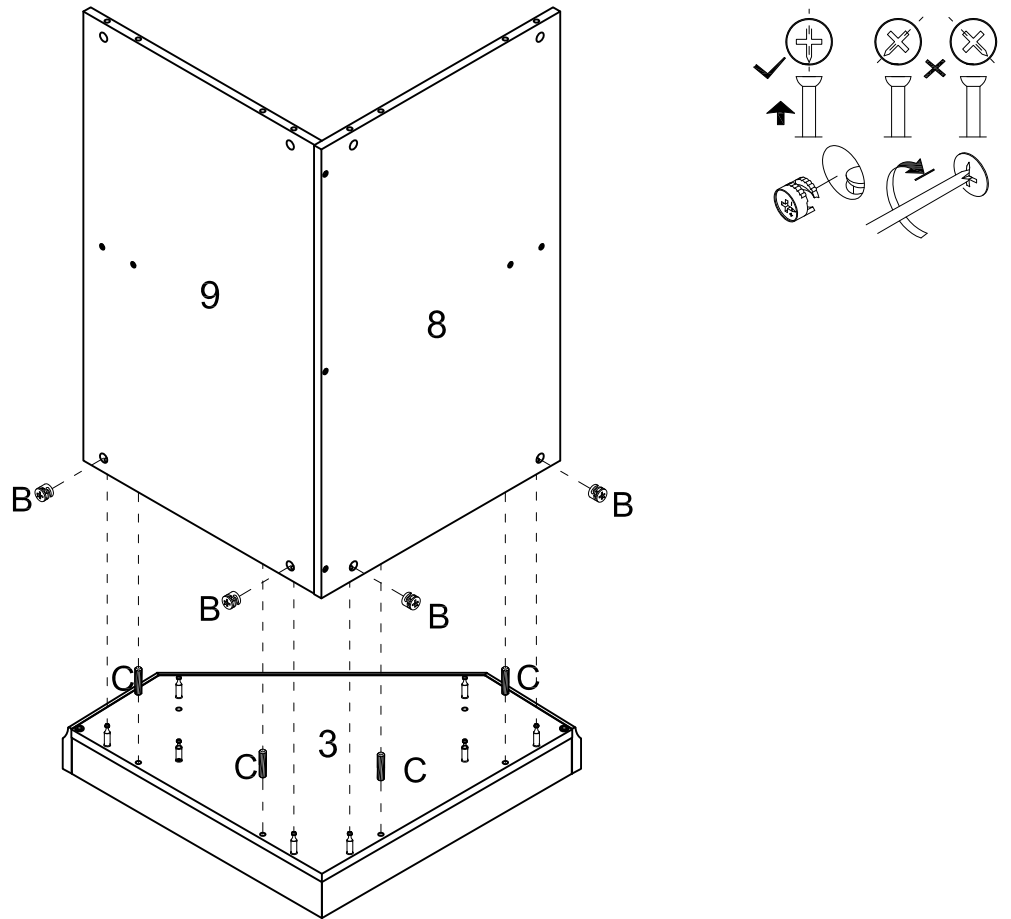

Step 24

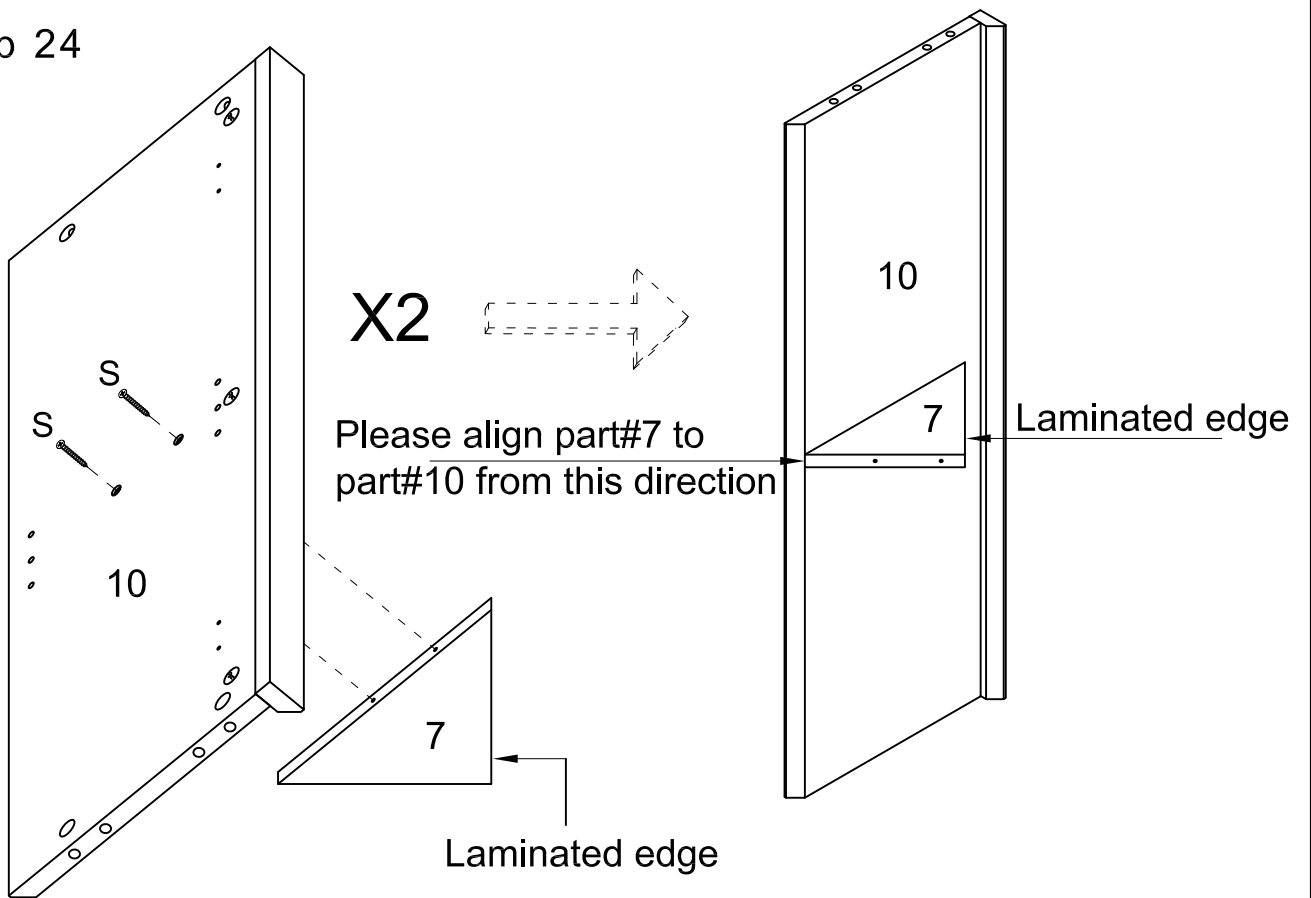

Step 25

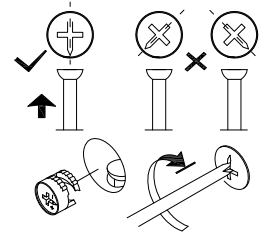
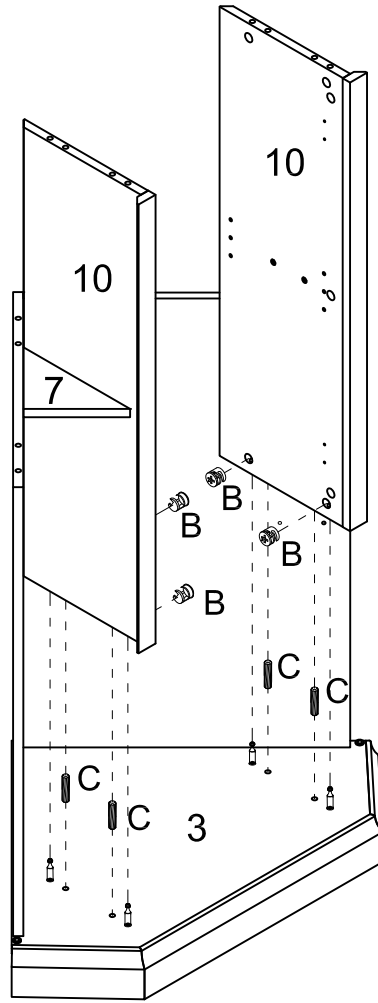

Step 26

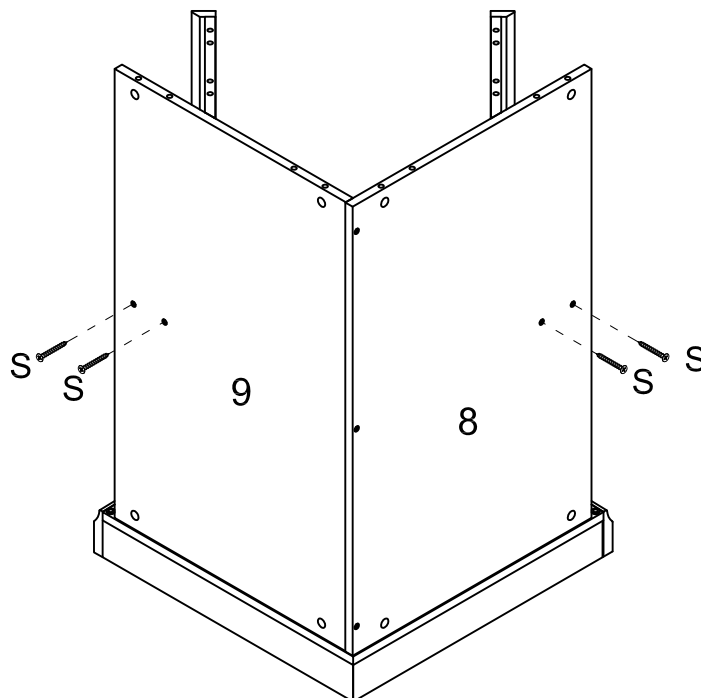

Step 27

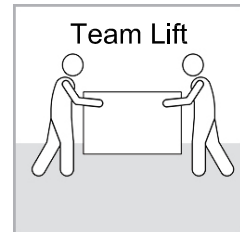
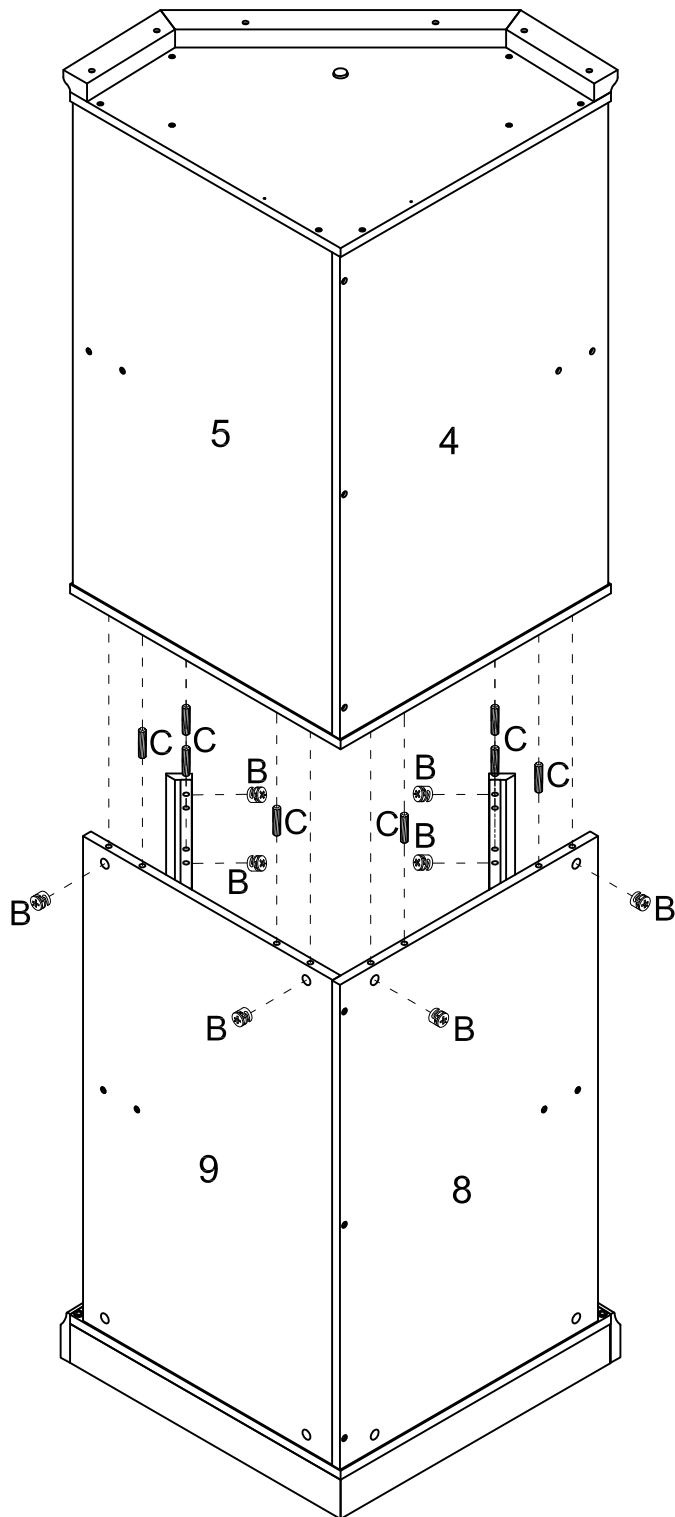
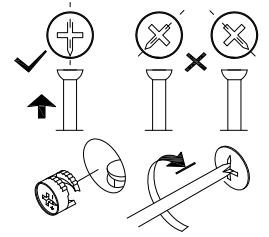

Make sure you have at least two people to put the top onto the base.

Step 28

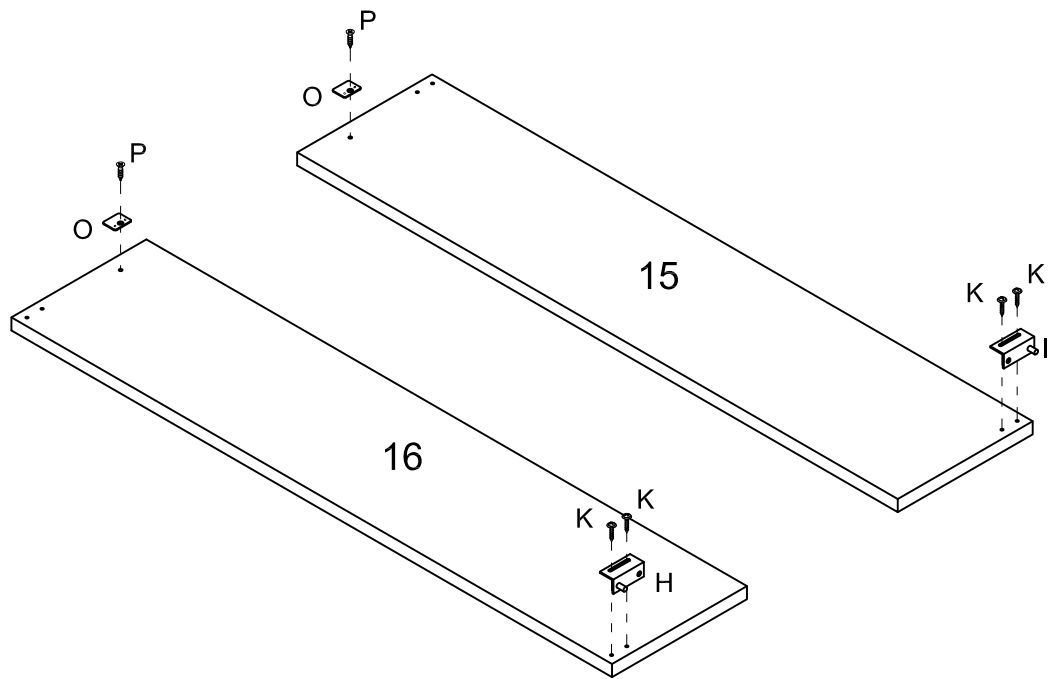

Step 29

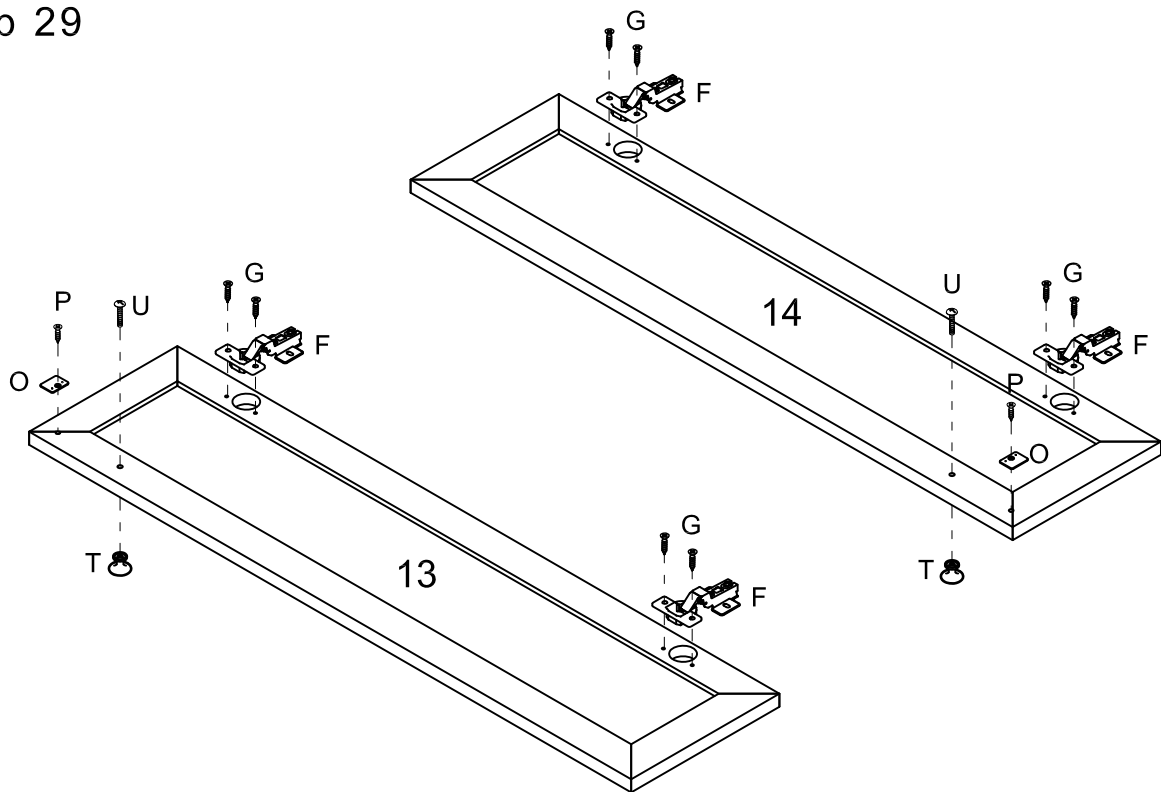

Step 30

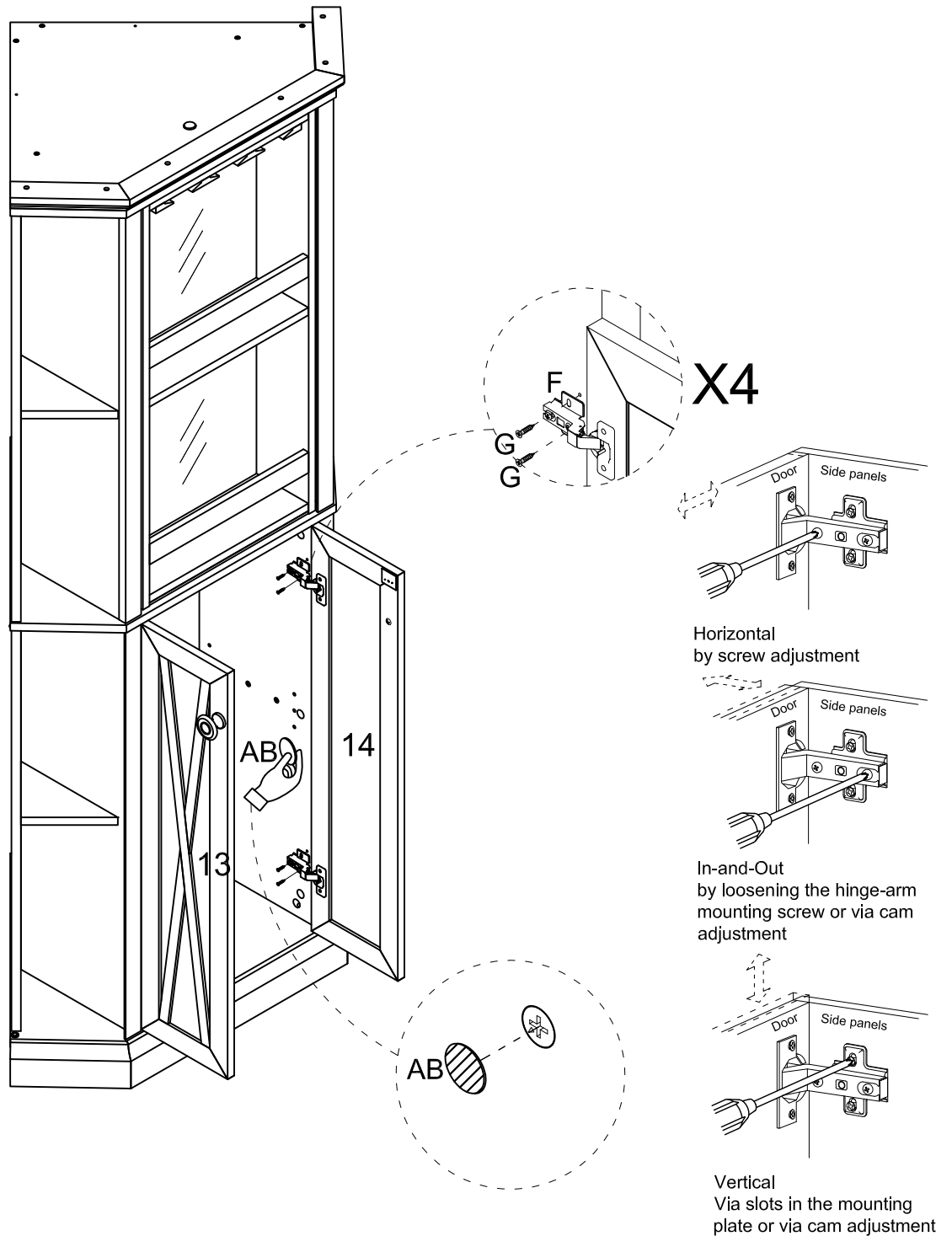

Place sticker (AB) to cover the holes as per diagram.

Step 31

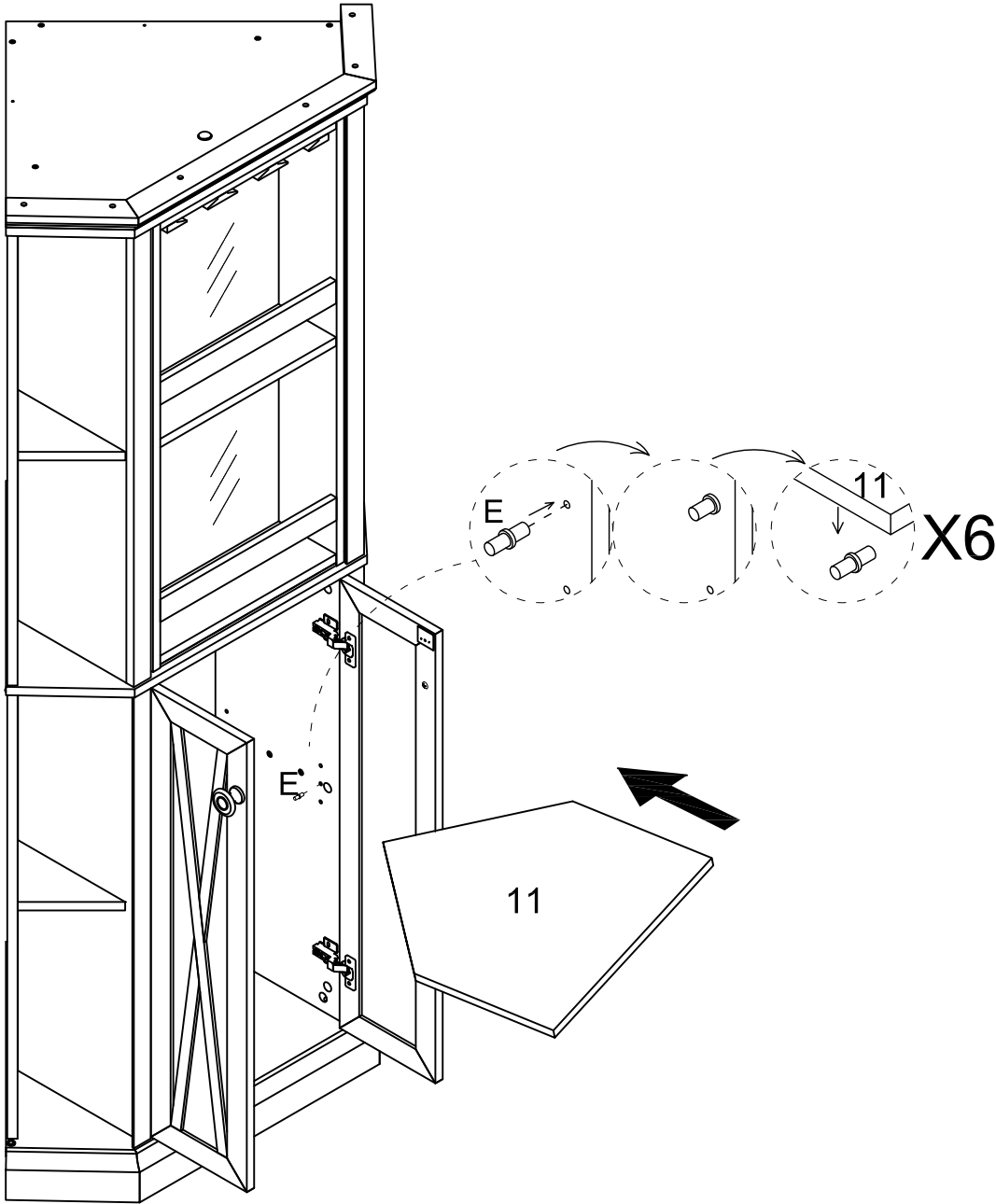

Step 32

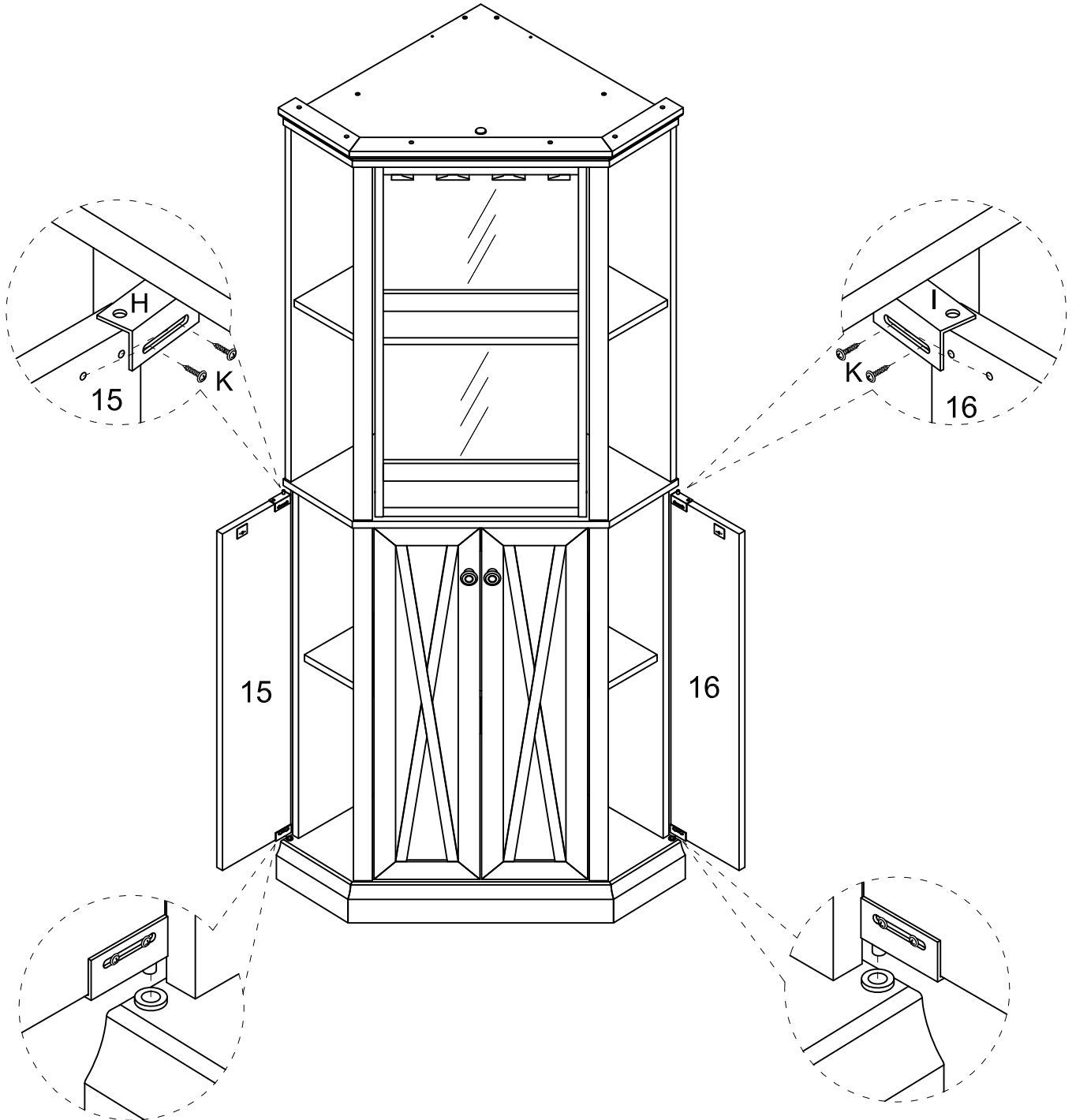

Step 33

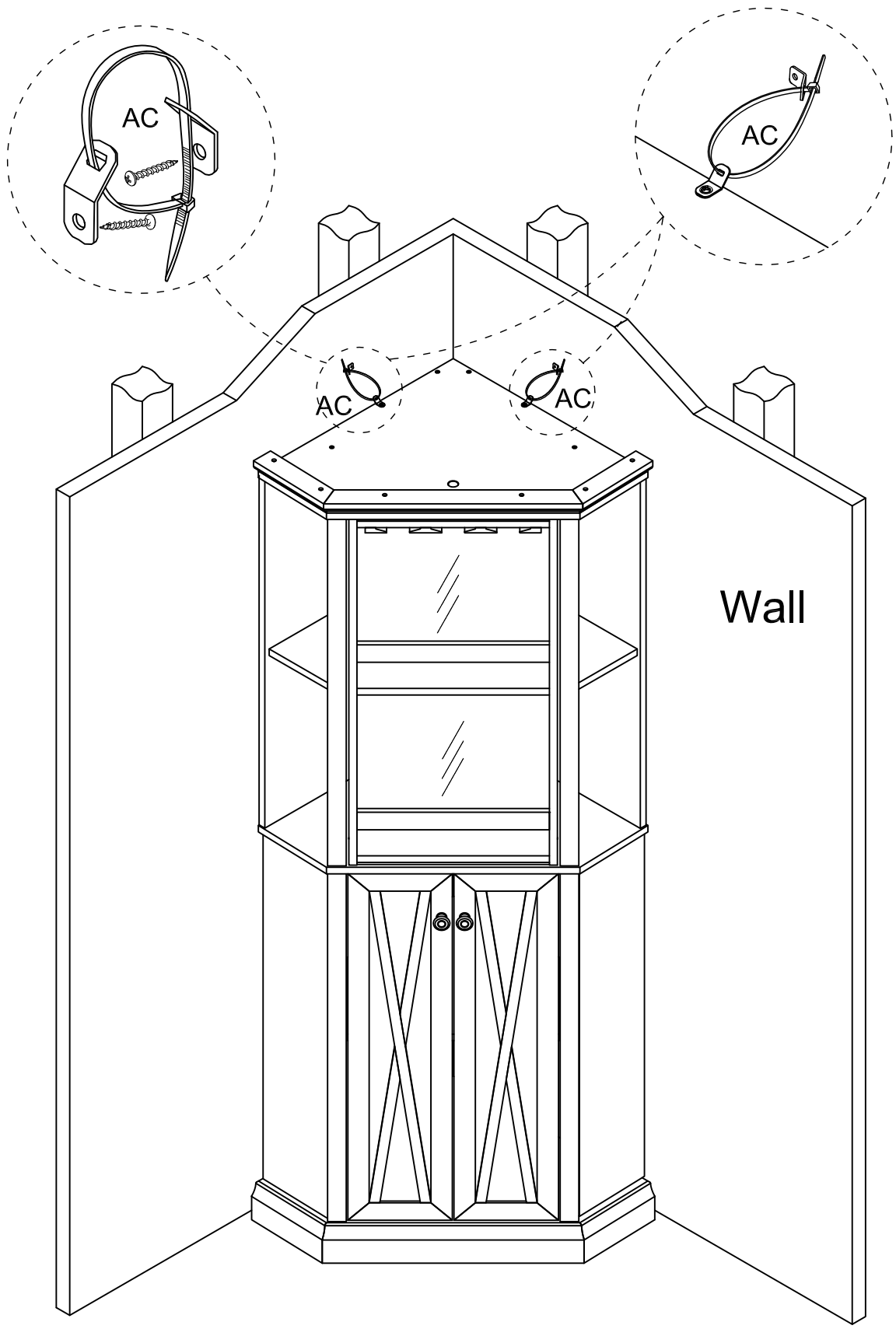

Final Assembly