

HOME SOURCE®

ASSEMBLY INSTRUCTION

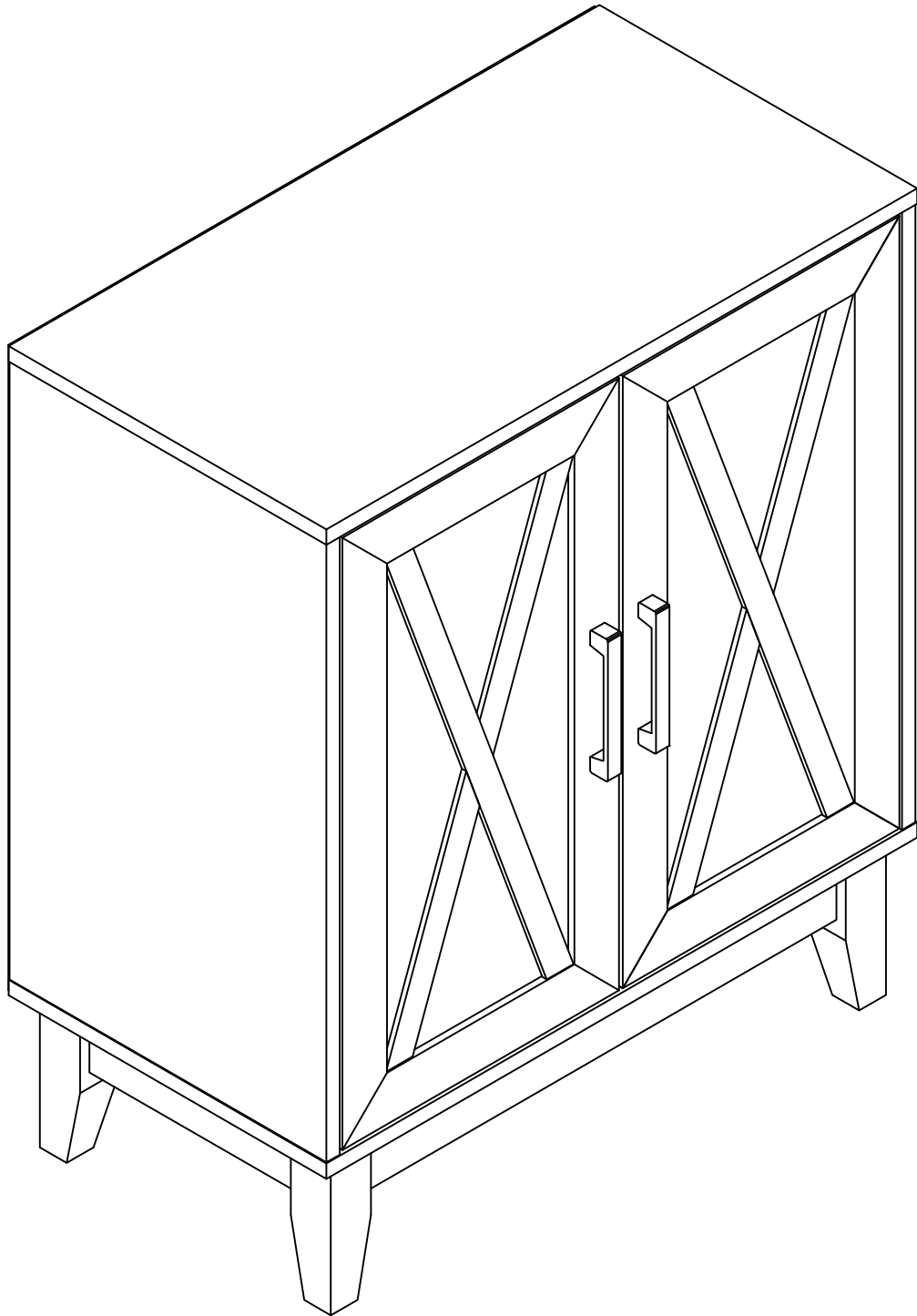





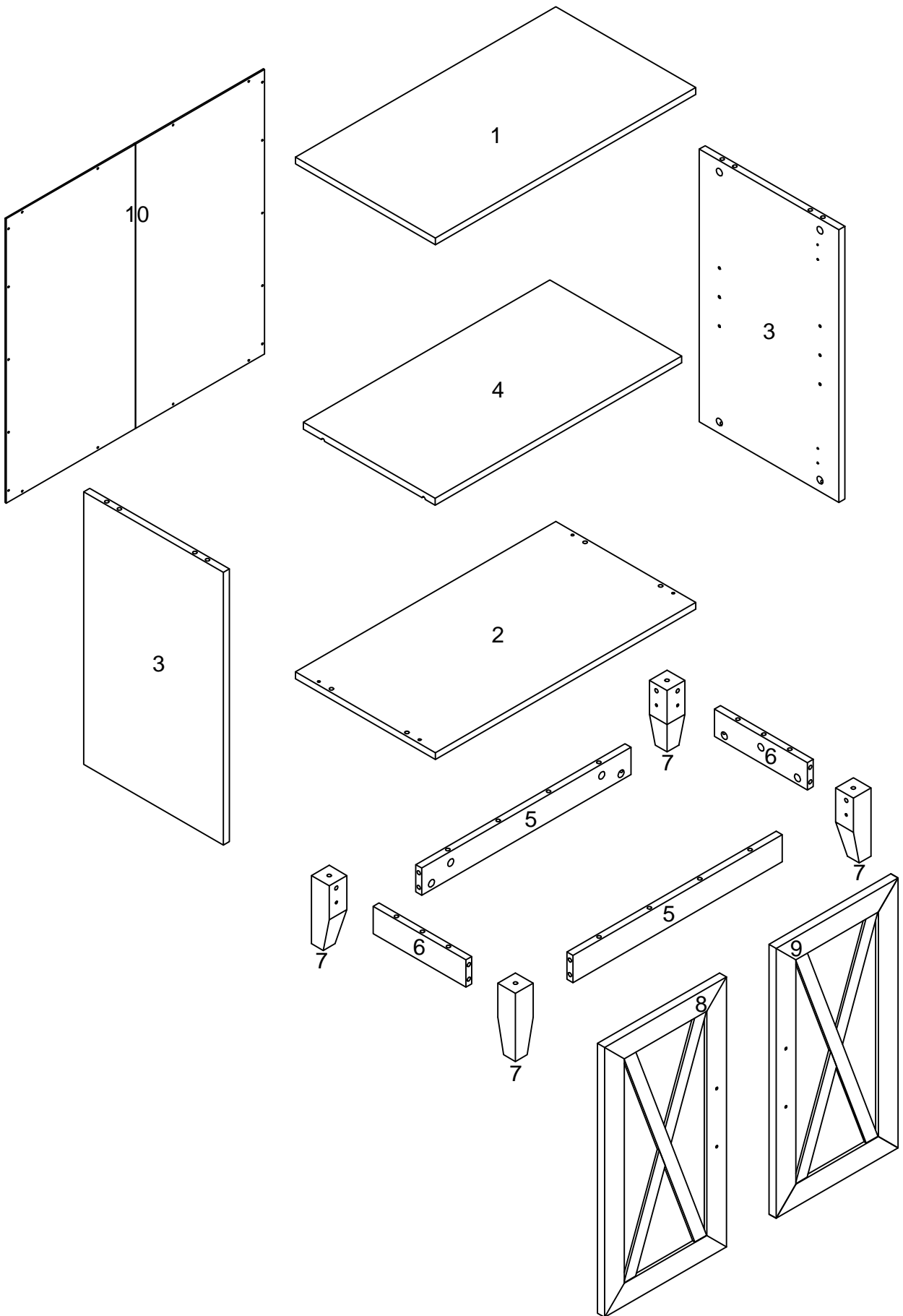









MODEL:JZ62 MOP

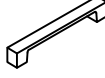

Parts List



Hardware List

A		Ø5*25mm	Bolt	22 pcs
B		Ø15*11mm	Nut	22 pcs
C		Ø8*30mm	Wood Dowel	28 pcs
D		Ø5*16mm	Shelf Support	4 pcs
E		Ø26mm	Hinge	4 pcs
F		Ø4*15mm	Screw	16 pcs
G		44x16x12mm	Magnet	1 pcs
H		Ø3.5*15mm	Screw	2 pcs
I		30x22x1mm	Iron Sheet	2 pcs
J		Ø3*12mm	Screw	2 pcs
K		137*15*19mm	Handle	2 pcs
L		Ø4*22mm	Bolt	4 pcs
M		Ø3*15mm	Screw	18 pcs
N			Glue	1 pc
O			Paper Cover	10 pcs
P			Anti-Tipping Kit	2 sets

Step 1

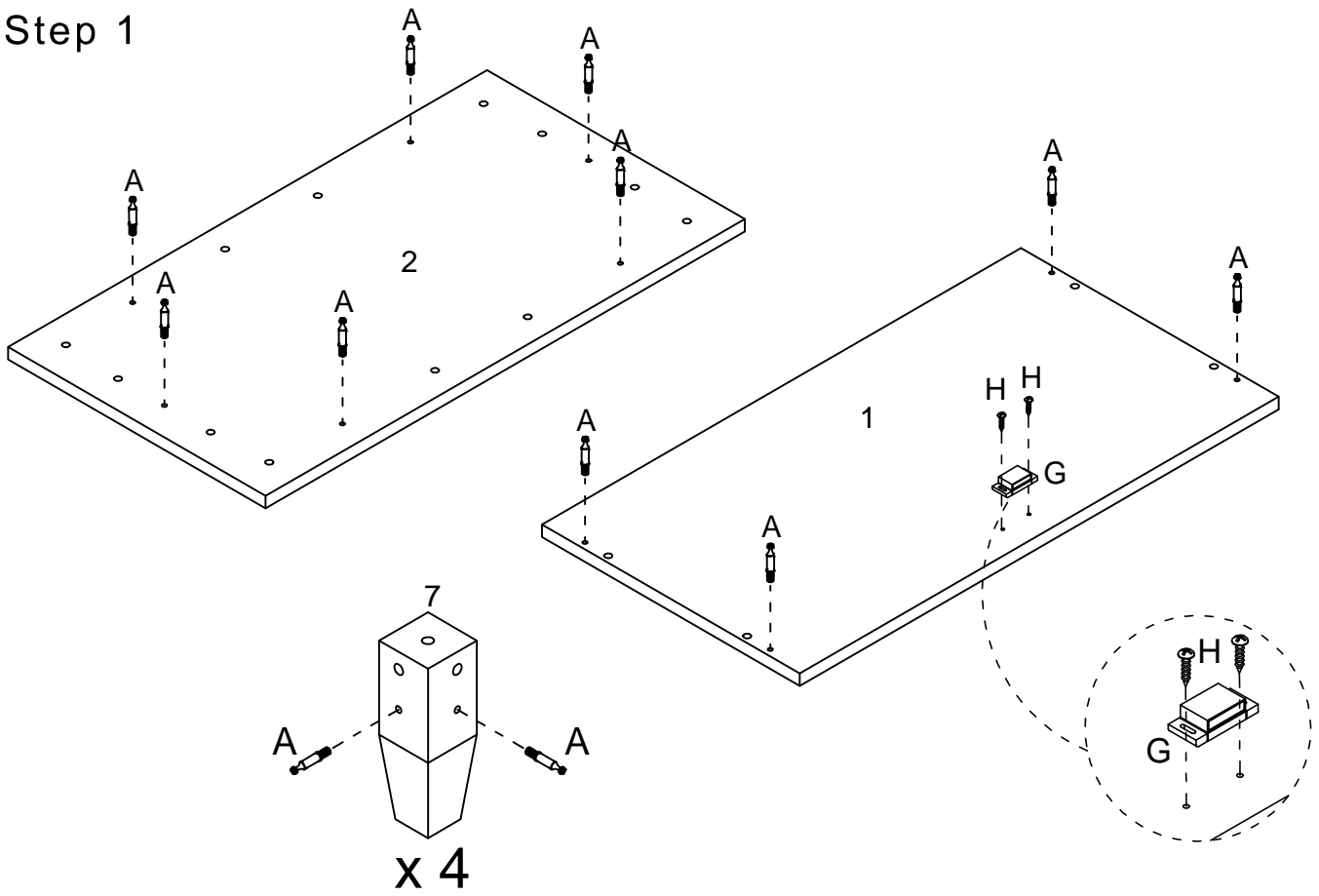

Step 2

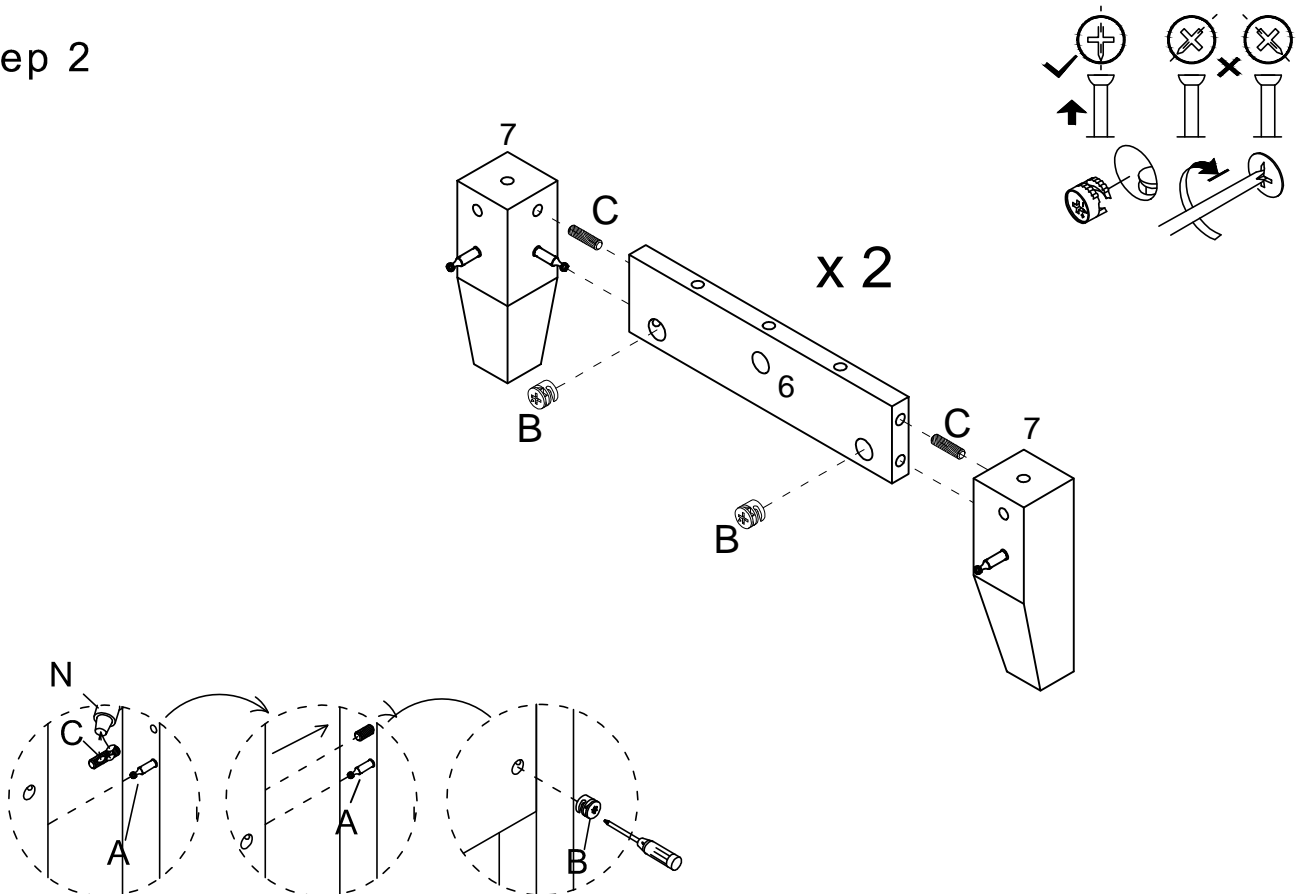

Step 3

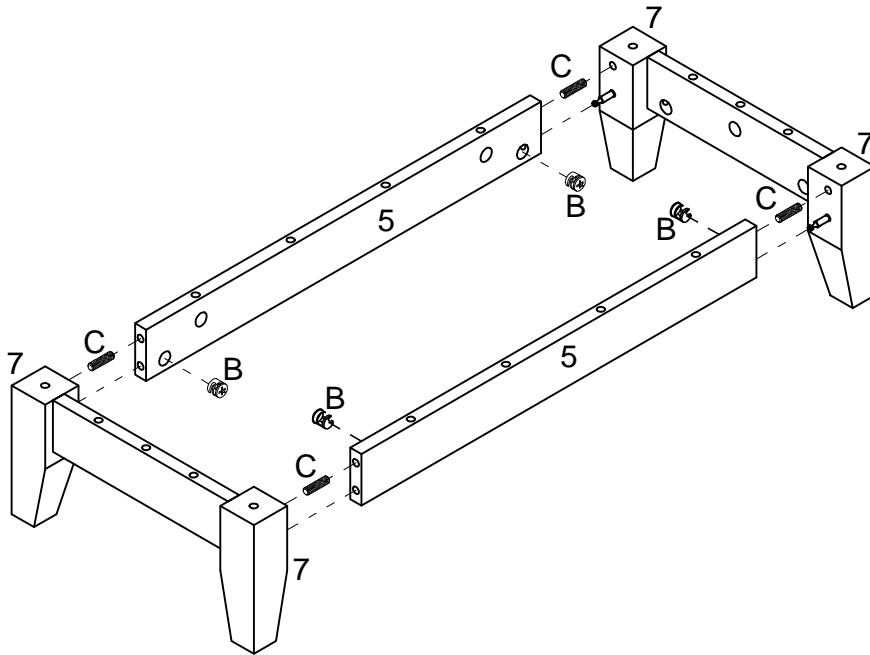
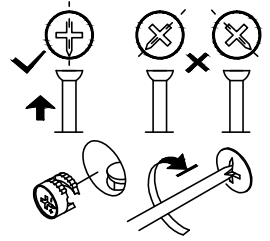

Step 4

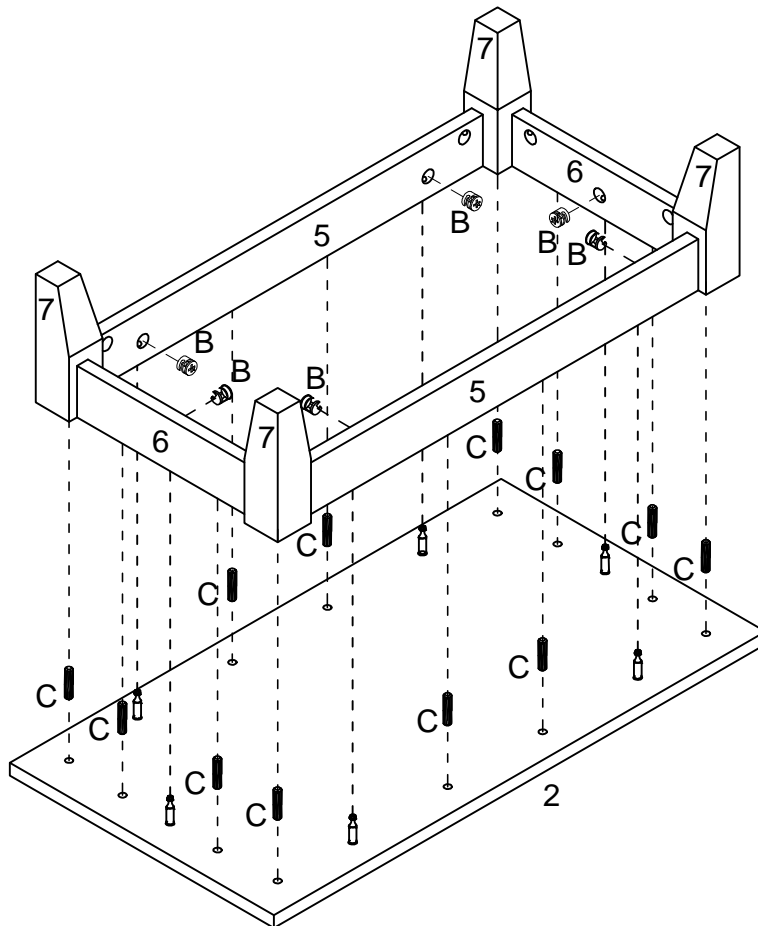
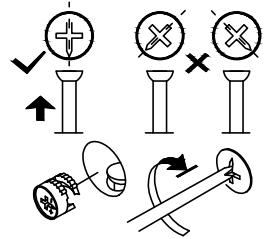

Step 5

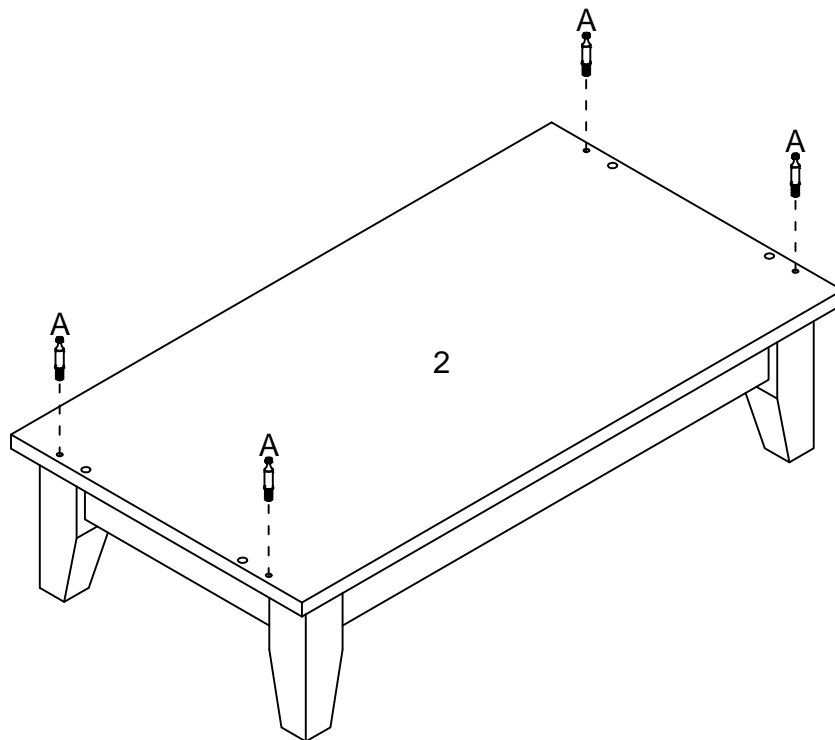

Step 6

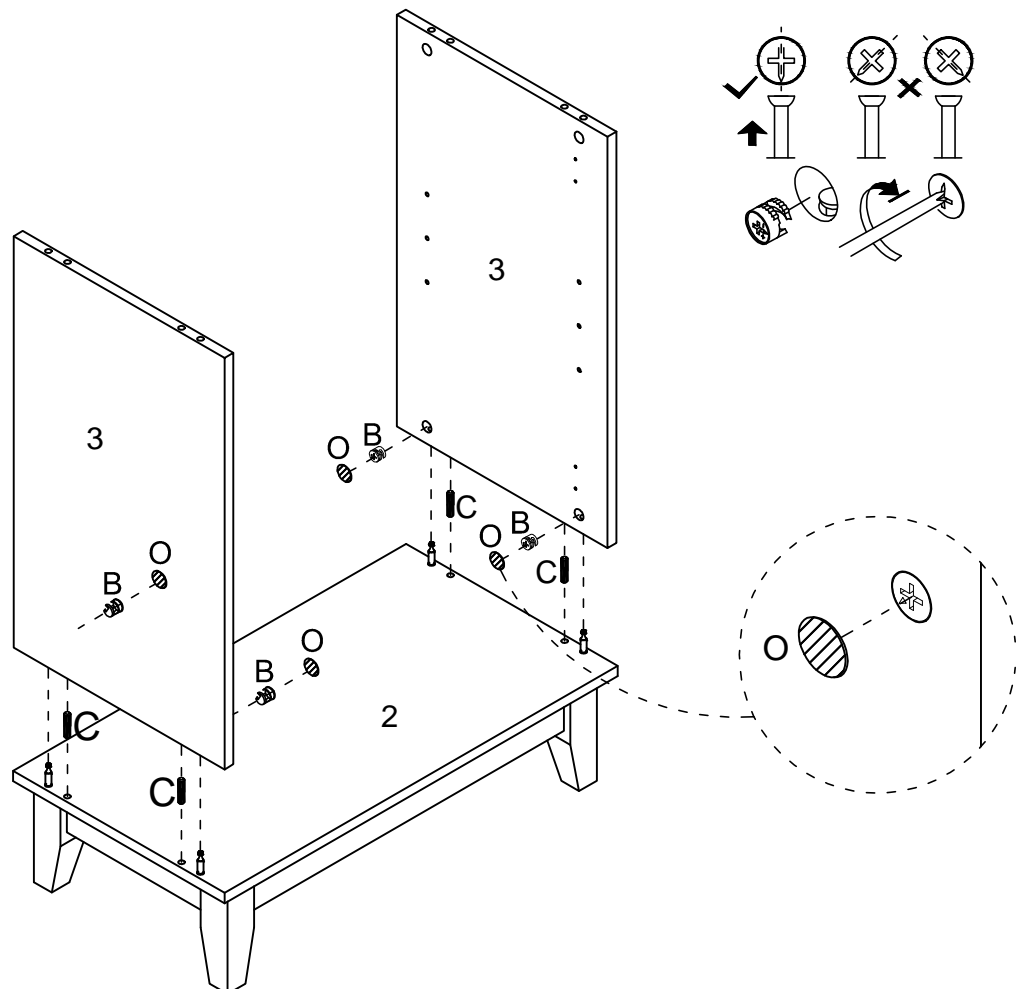

Step 7

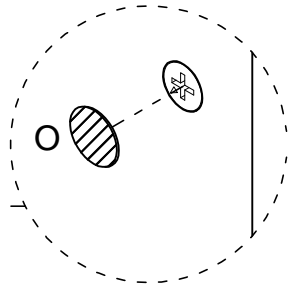
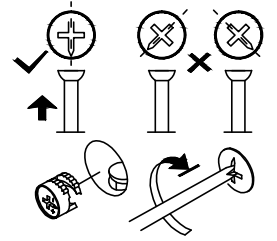
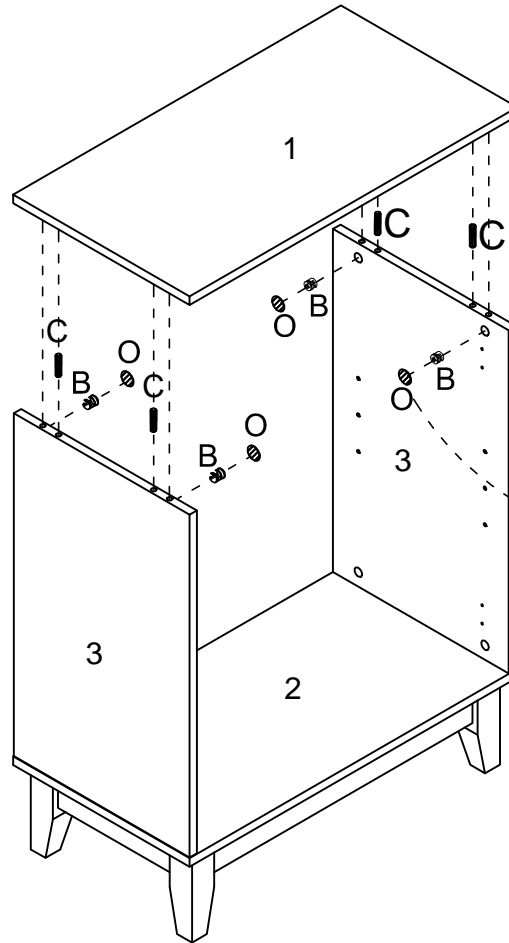

Step 8

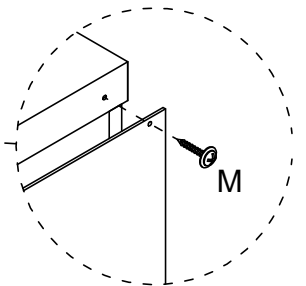
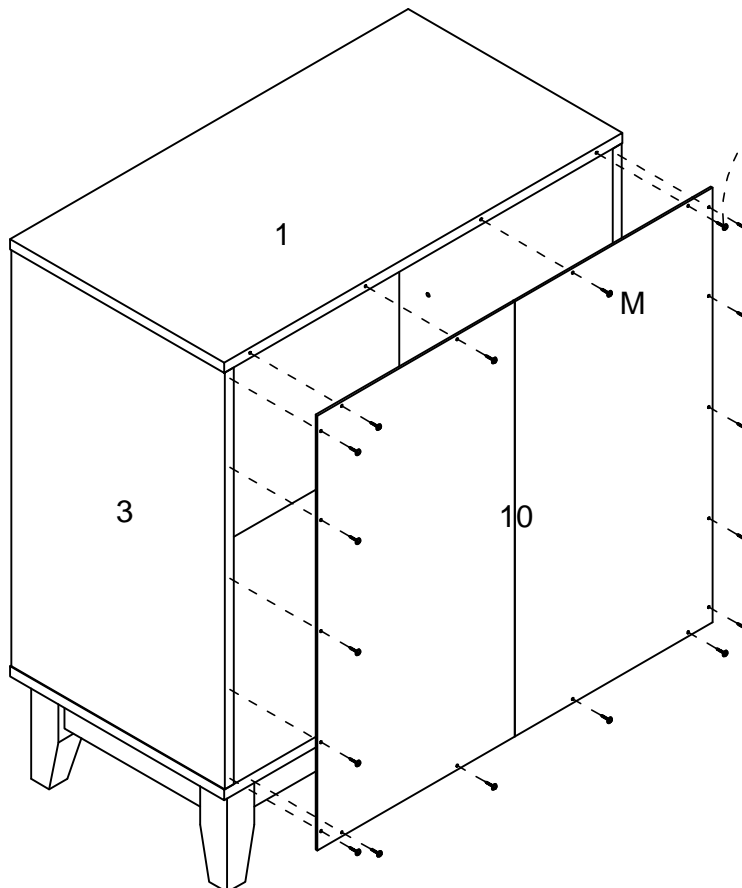

Step 9

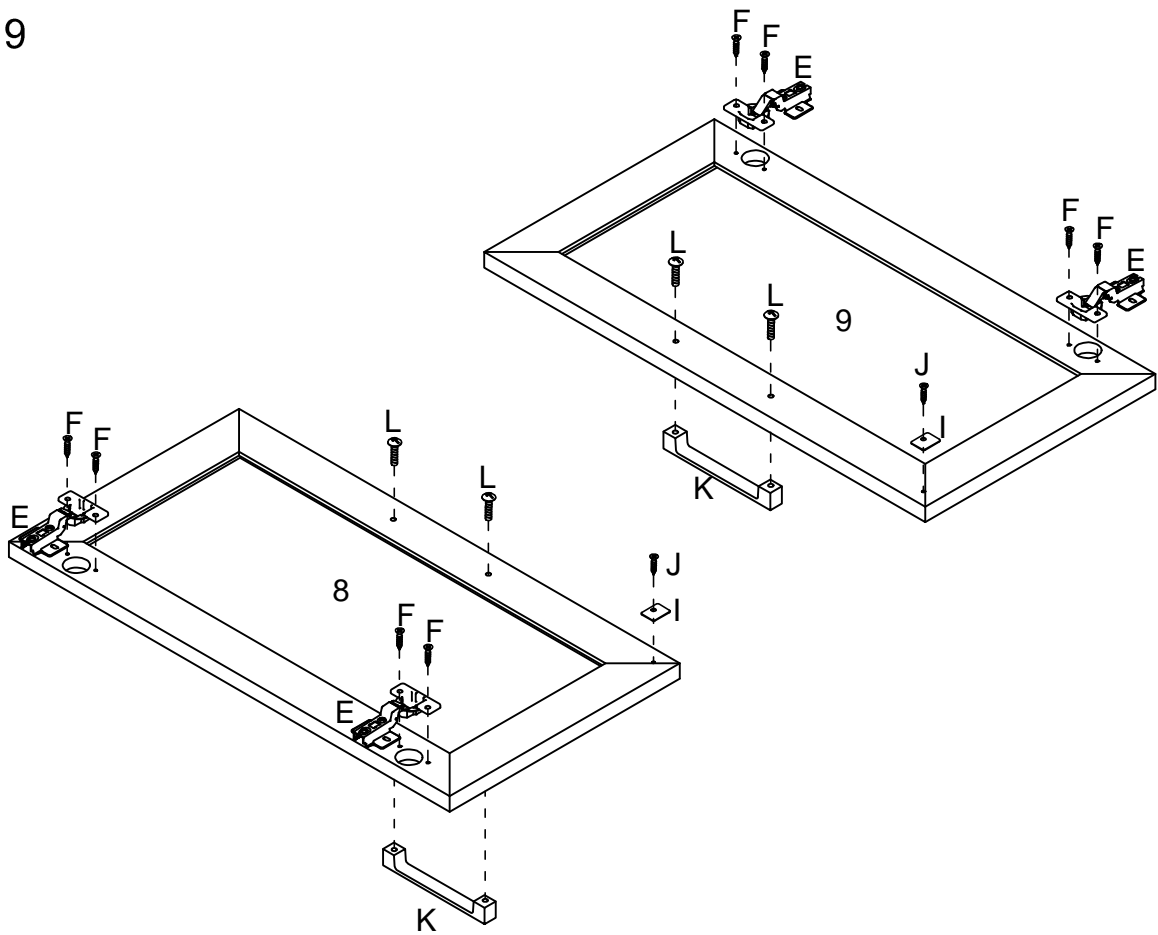

Step 10

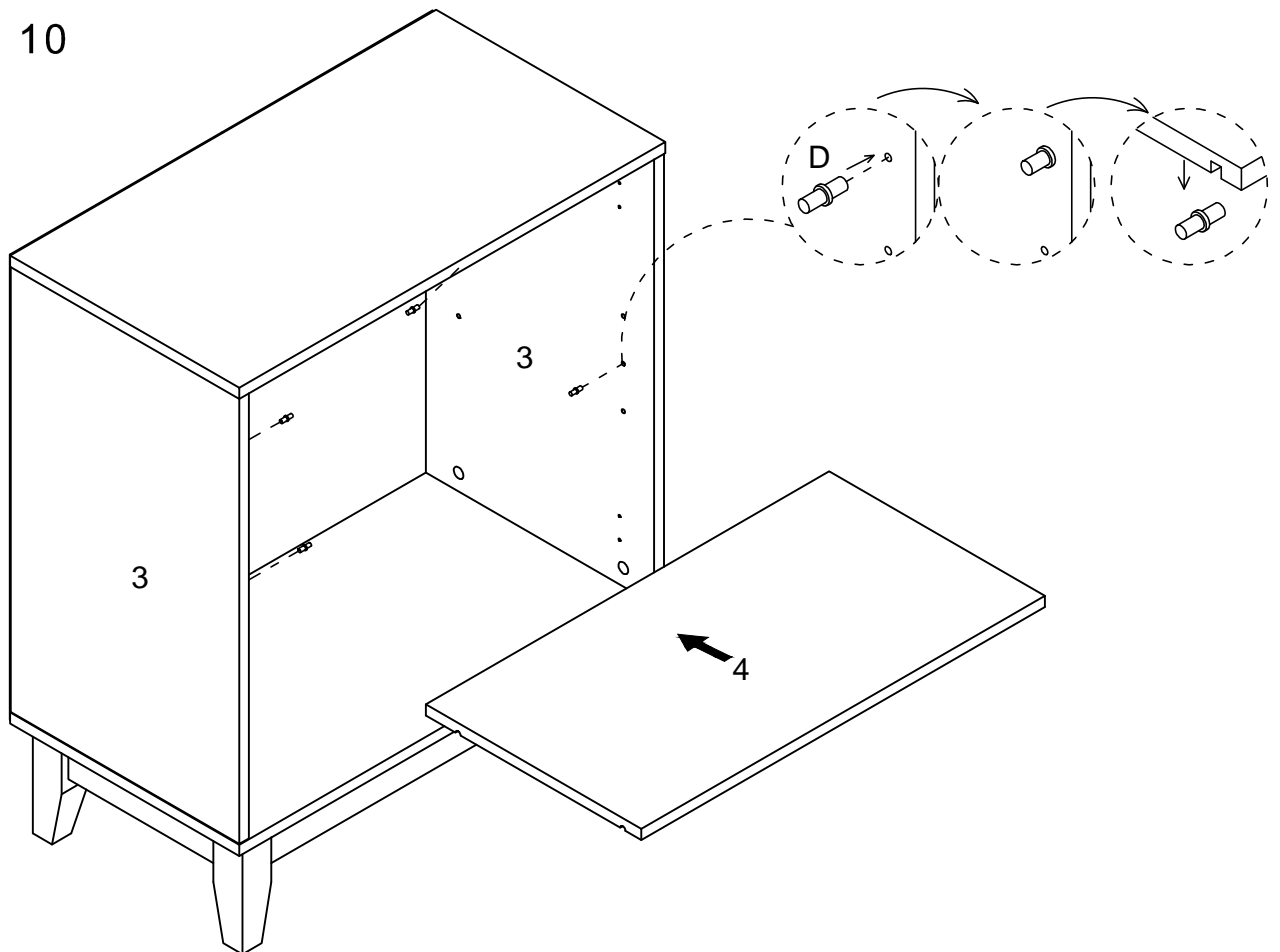

Step 11

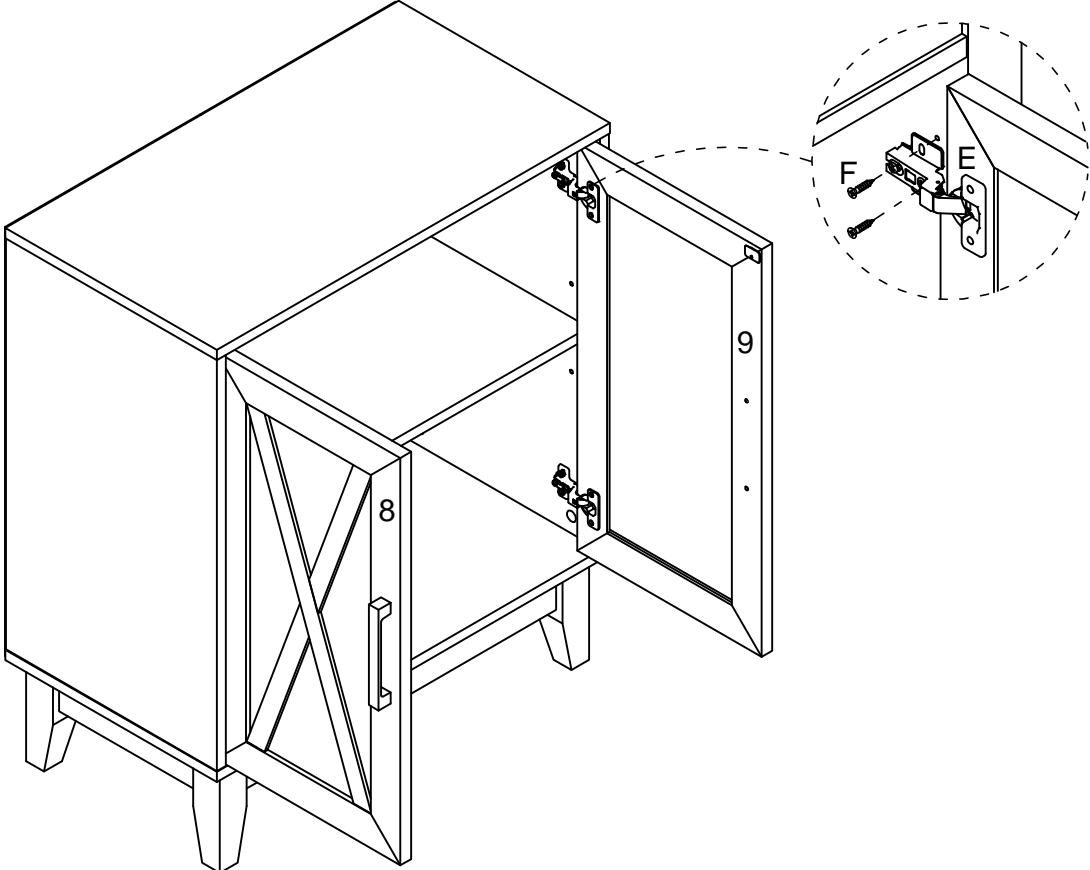

Step 12

