

HOME SOURCE®

ASSEMBLY INSTRUCTION

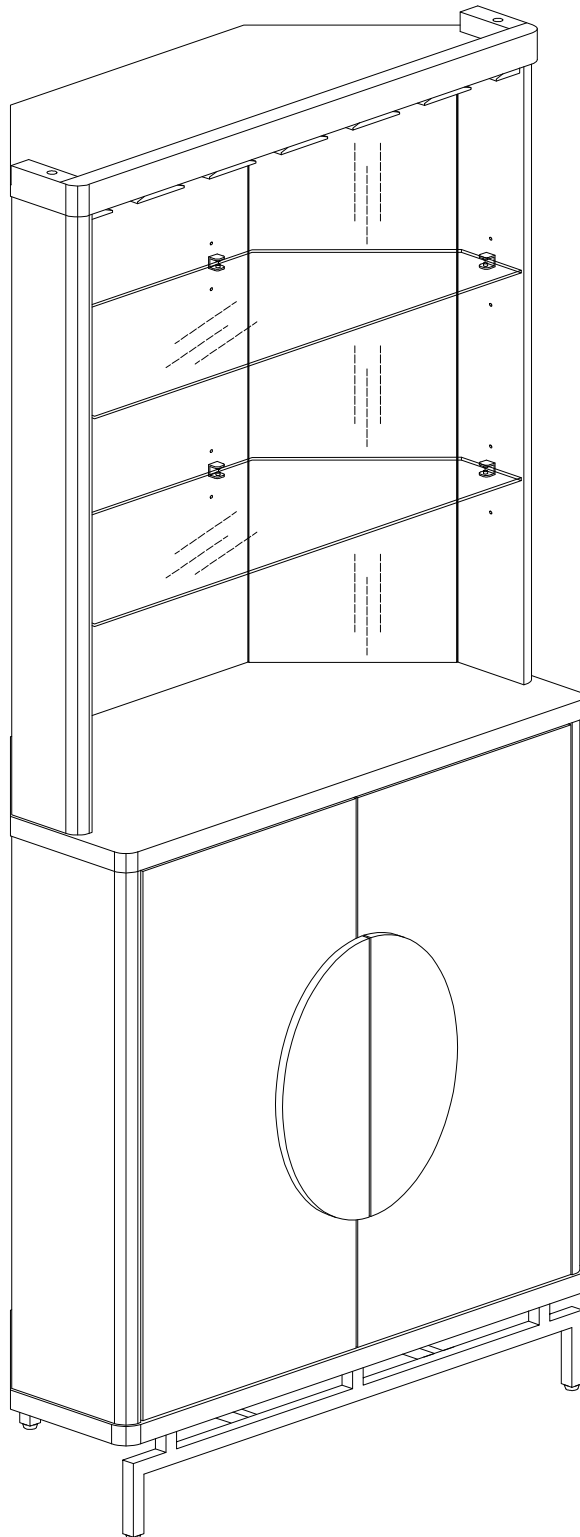





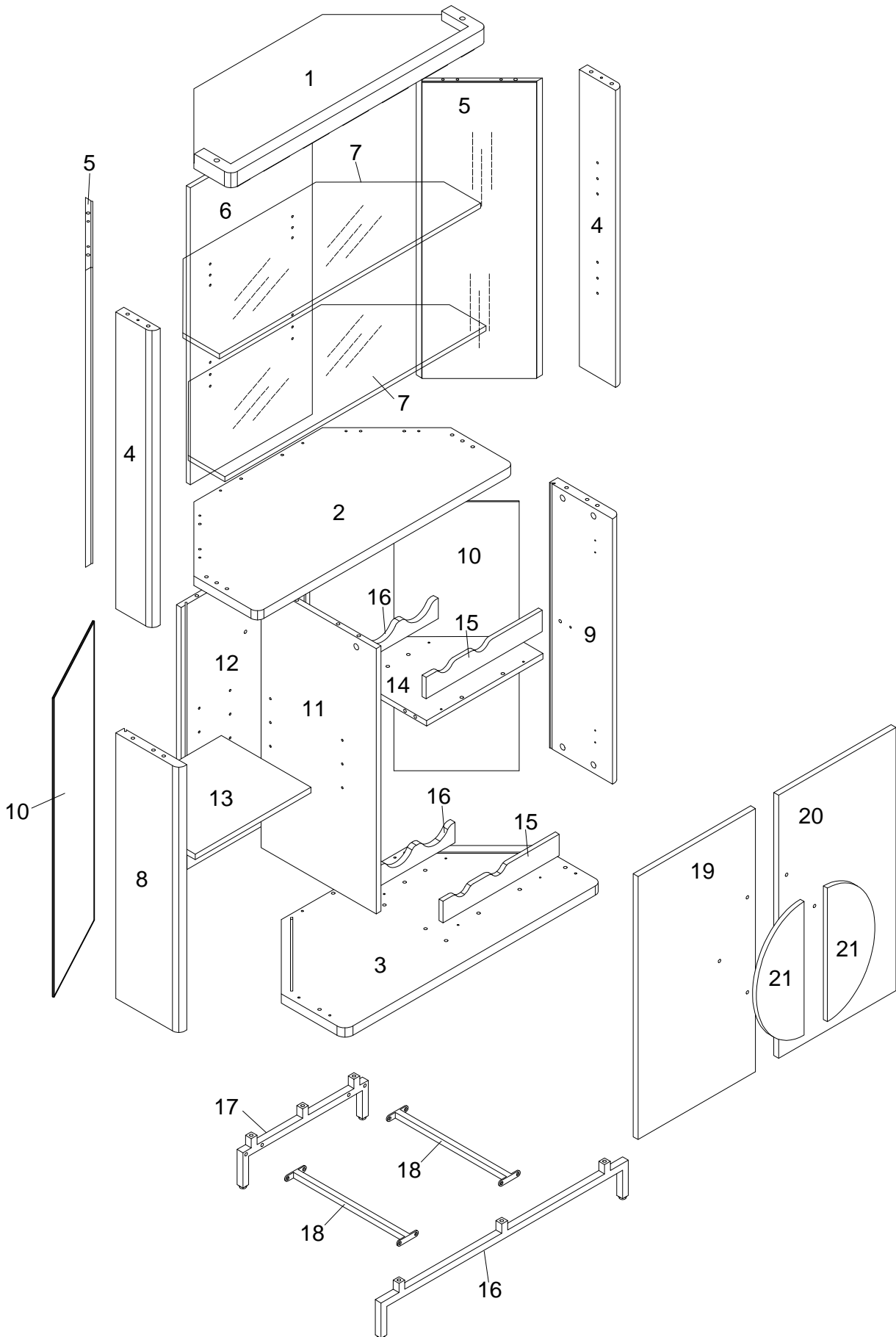



















MODEL:DC77 MOP



Parts List



Hardware List

A		Ø5*25mm	Bolt	29 pcs
B		Ø15*11mm	Nut	17 pcs
C		Ø15*9mm	Nut	12 pcs
D		Ø8*30mm	Wood Dowel	31 pcs
E		Ø6*30mm	Wood Dowel	12 pcs
F		Ø6*50mm	Bolt	8 pcs
G		M4	Allen Key	1 pc
H			Glass support	8 sets
I		Ø5*16mm	Shelf Support	5 pcs
J		Ø26mm	Hinge	4 pcs
K		Ø4*15mm	Screw	16 pcs
L		Ø4*30mm	Screw	4pcs
M		Ø4*38mm	Screw	4 pcs
N		Ø16*Ø8.5*10mm	The gasket	6 pcs
O		Ø3*17mm	Screw	8 pcs
P			Back Clip	8 pcs
Q		44*16*12mm	Magnet	2 pcs
R		Ø3.5*15mm	Screw	4 pcs
S		30x22x1mm	Iron Sheet	2 pcs
T		Ø3*12mm	Screw	2 pcs
U			Glue	1 pc
V			Paper Cover	10 pcs
W			Anti-Tipping Kit	2 sets
X		1/4*30mm	Bolt	6 sets
Y		1/4*15mm	Bolt	8 sets
Z		1/4*55mm	Bolt	6 sets

Step 1

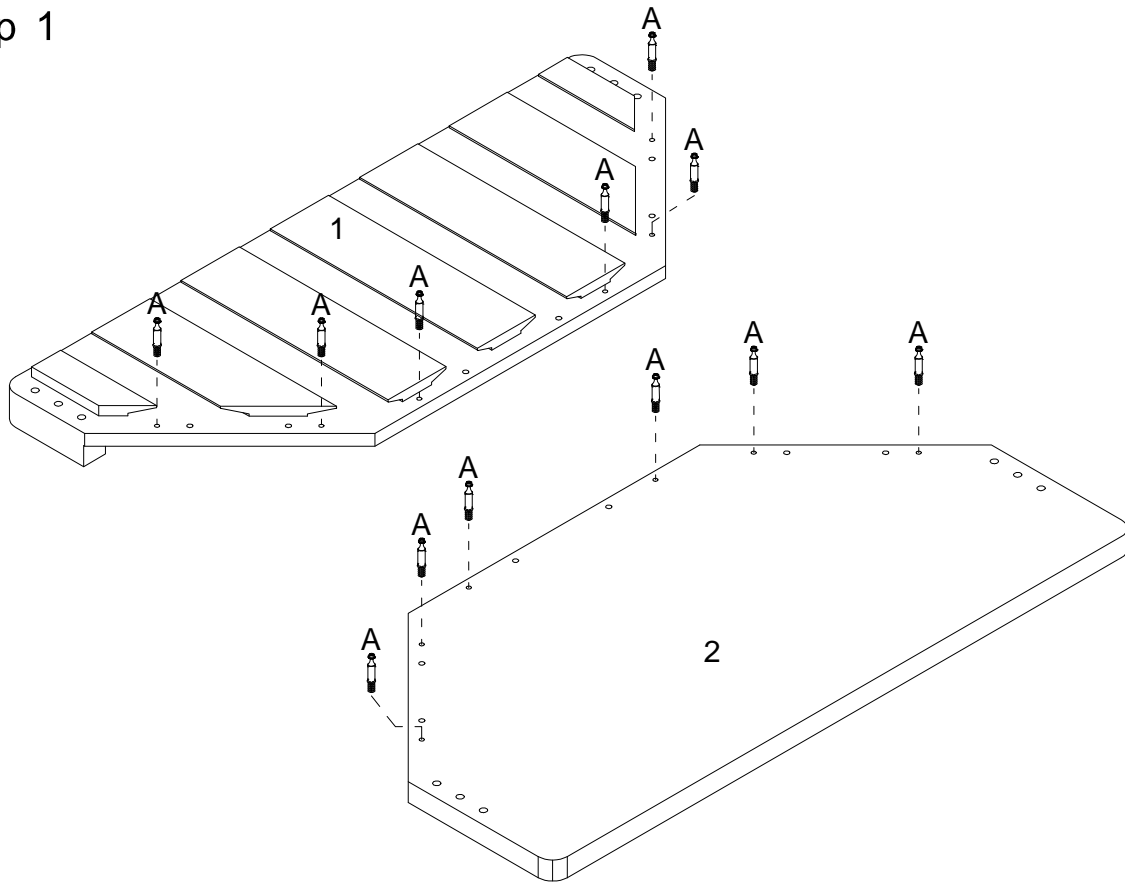

Step 2

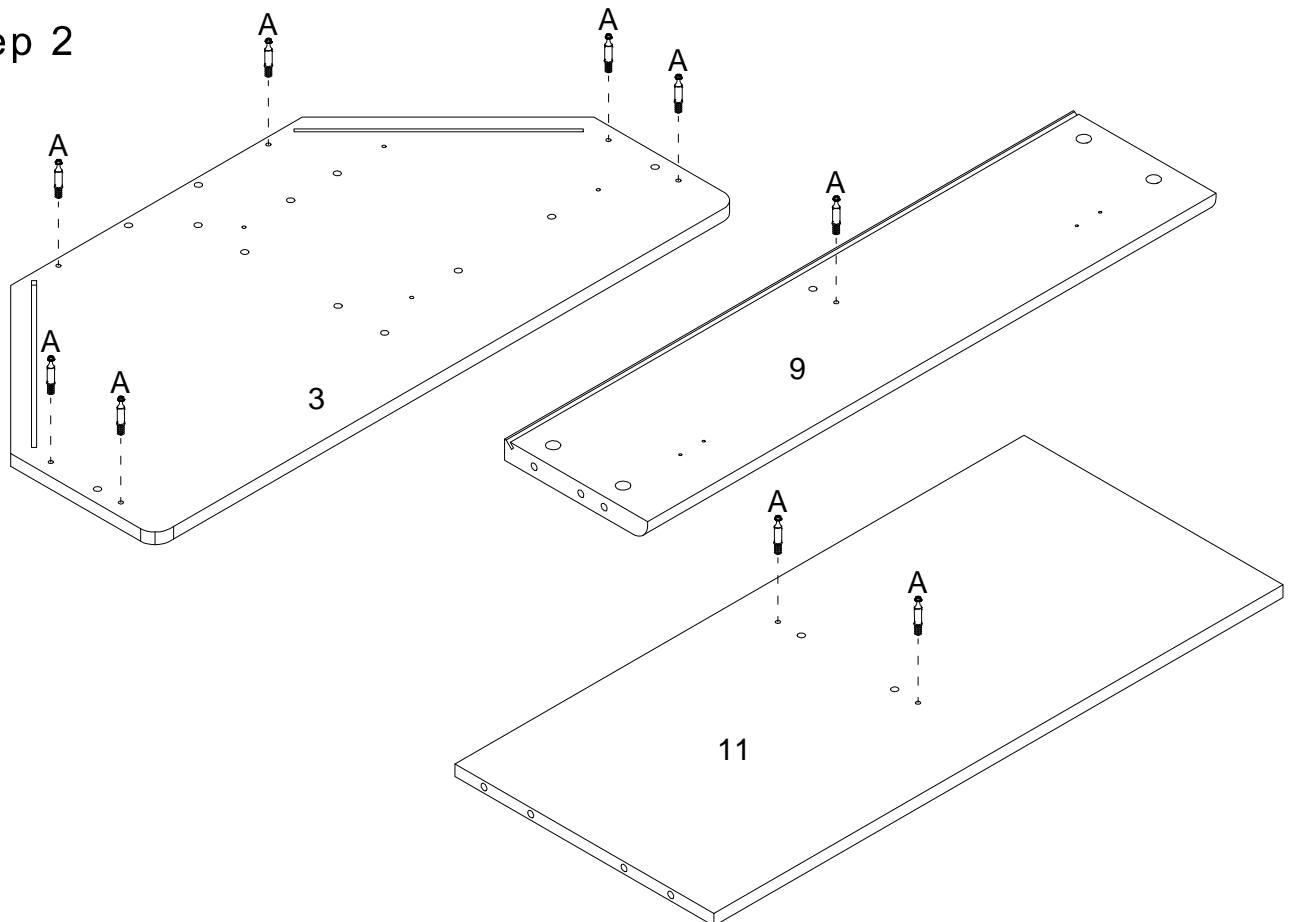

Step 3

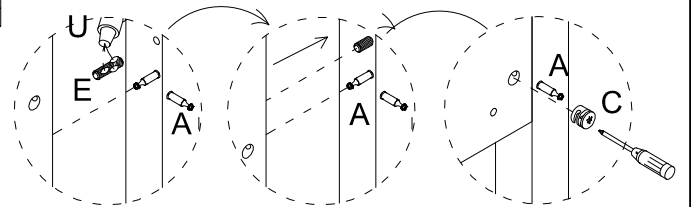
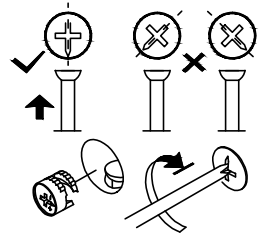
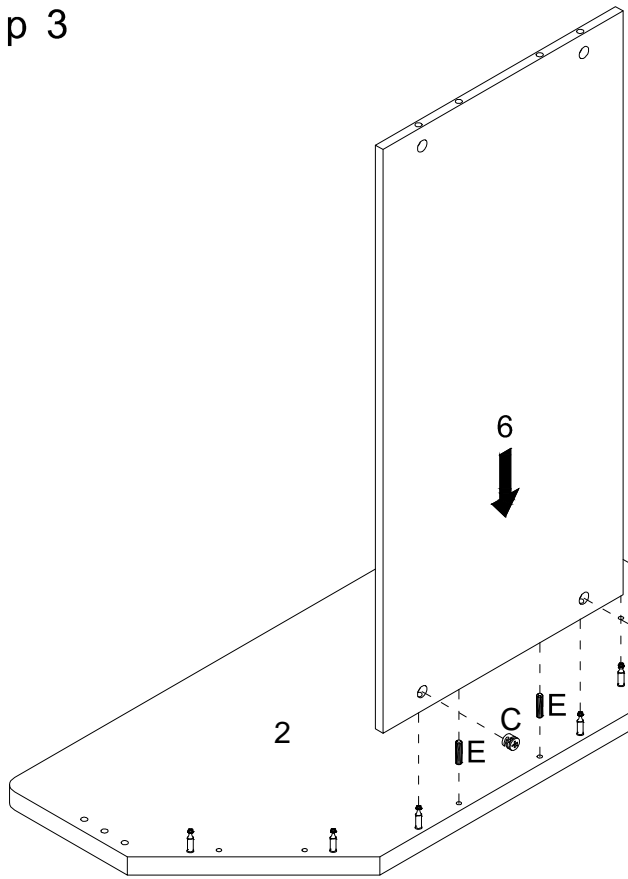

Step 4

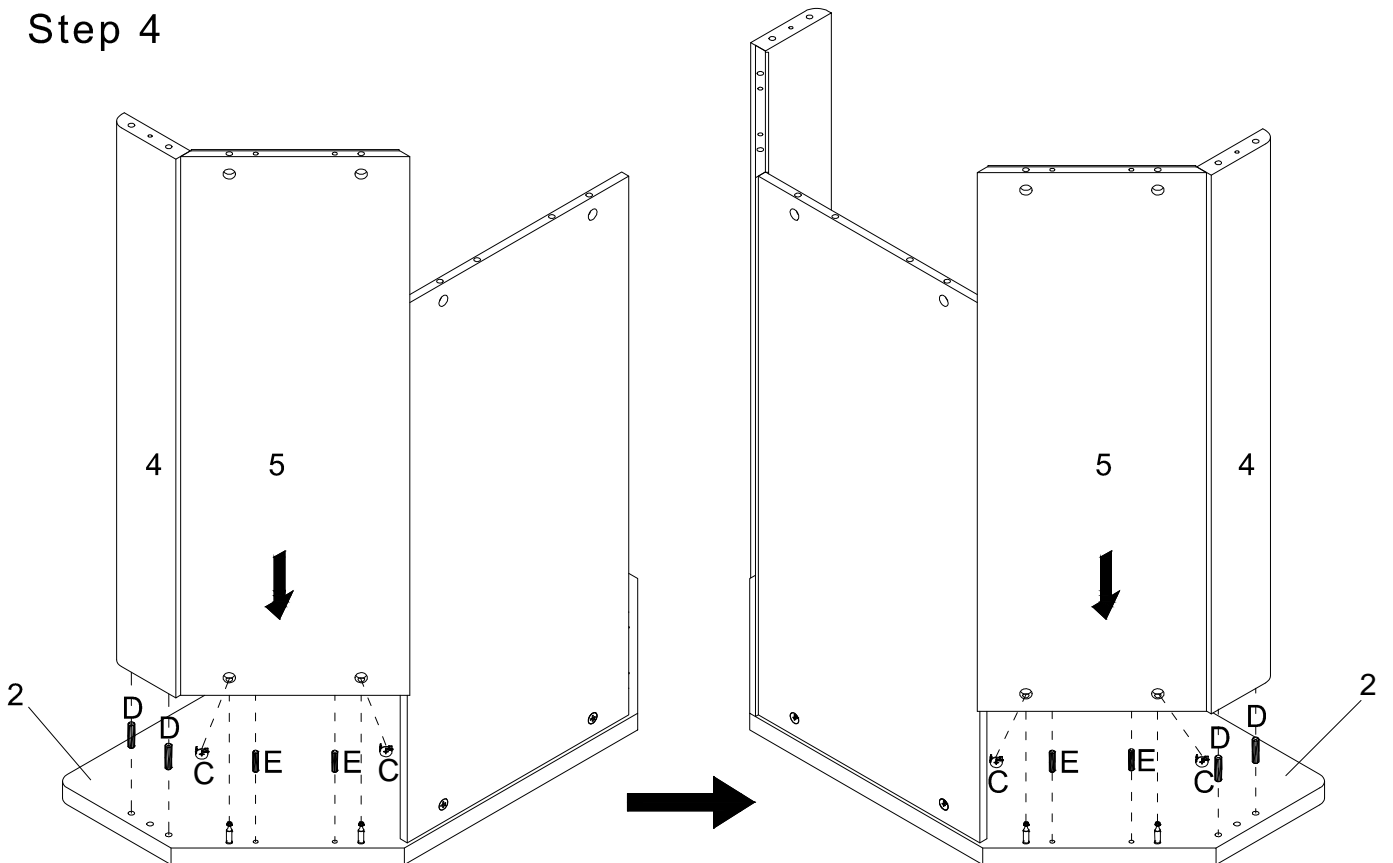

Step 5

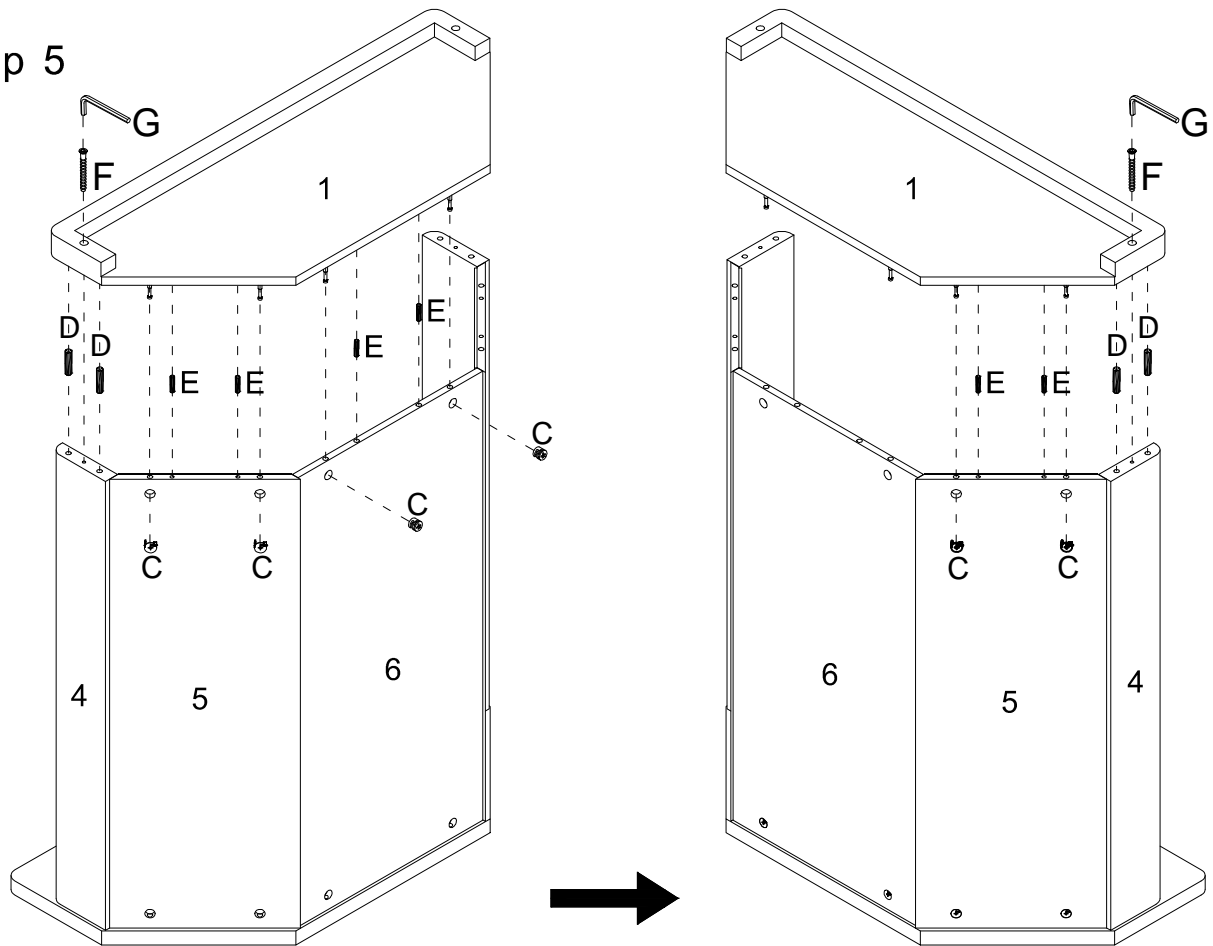

Step 6

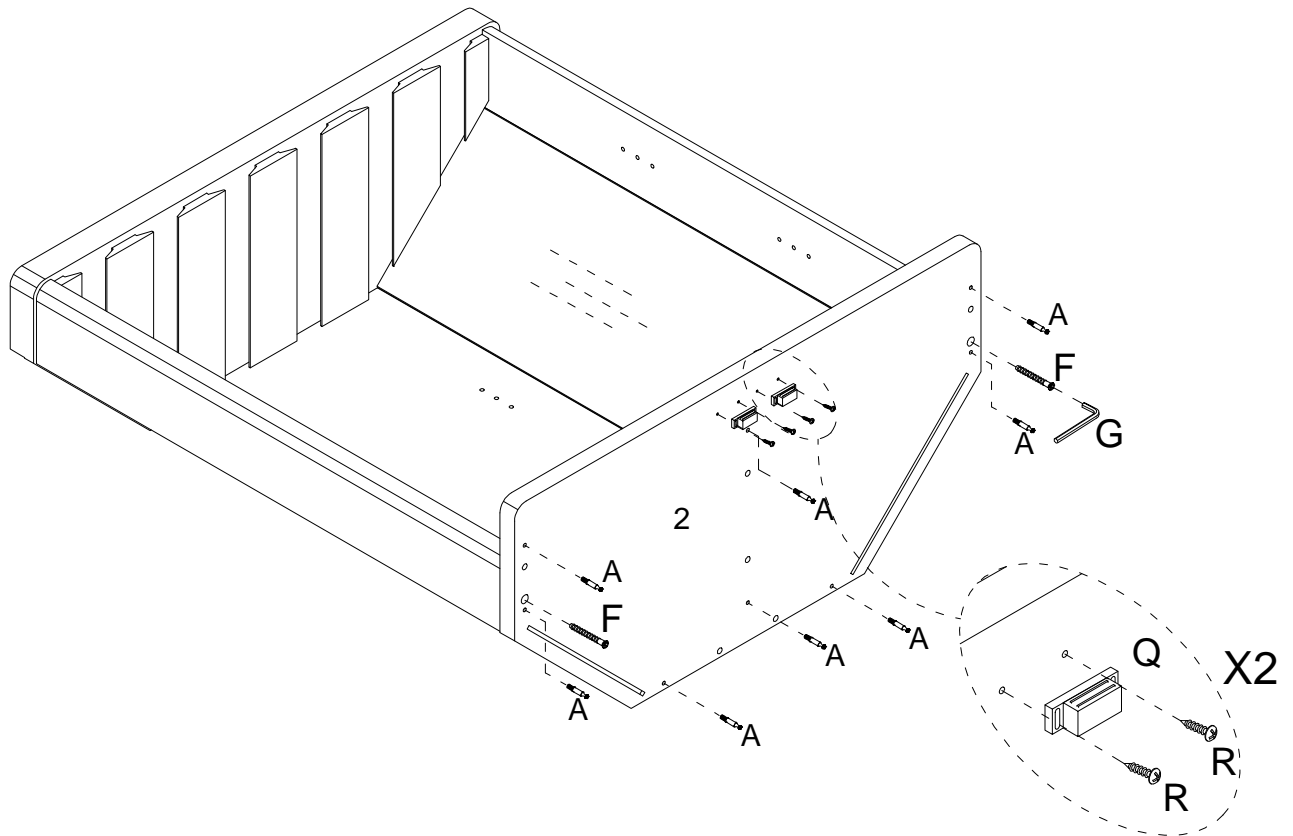

Step 7

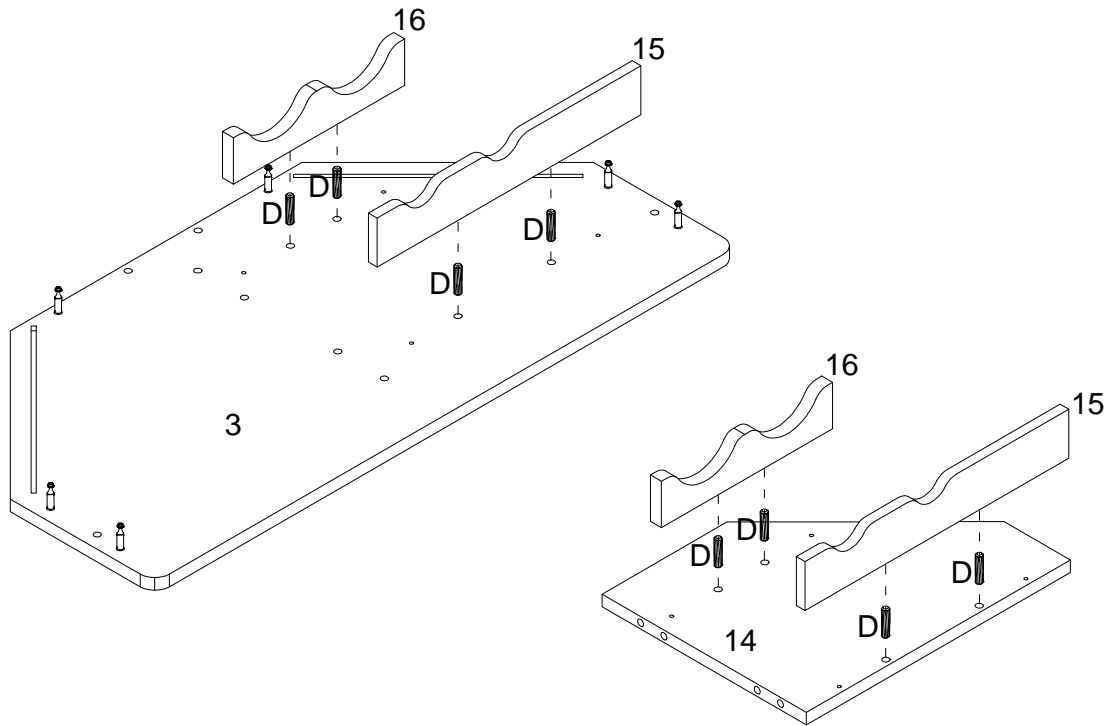

Step 8

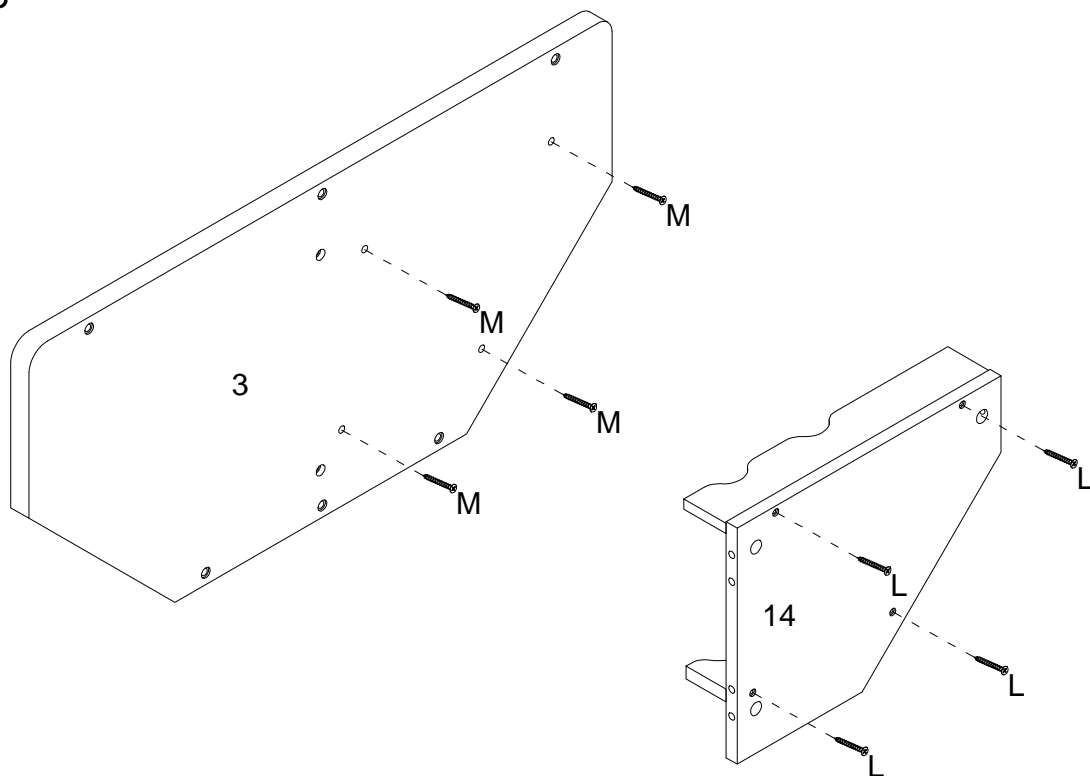

Step 9

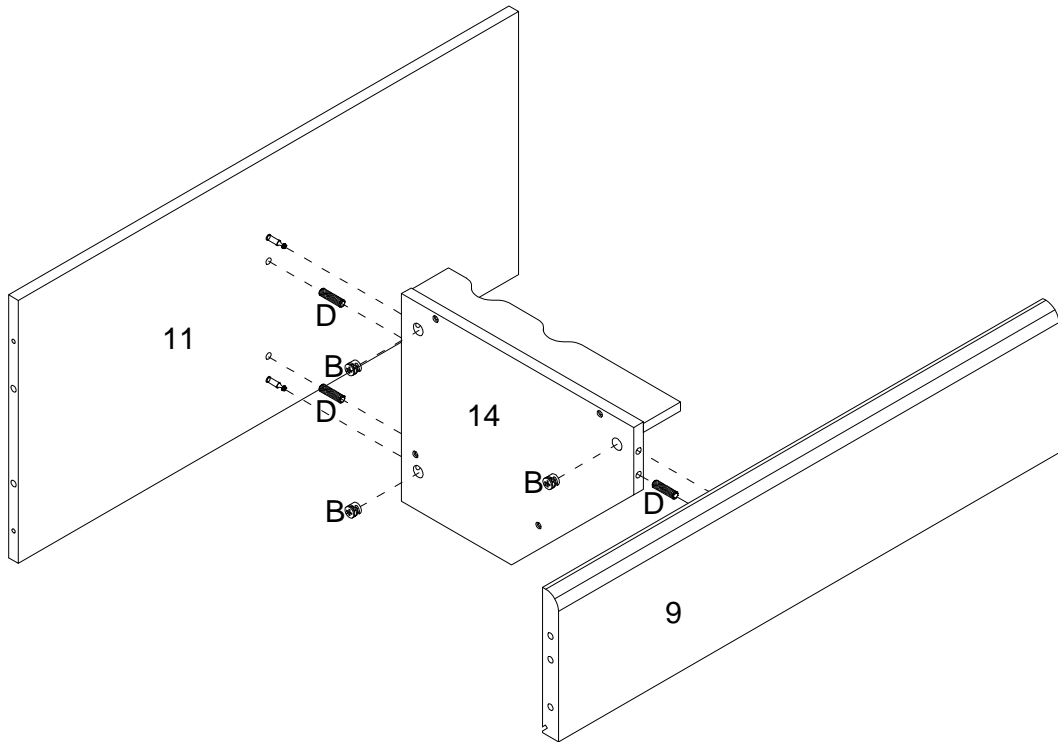

Step 10

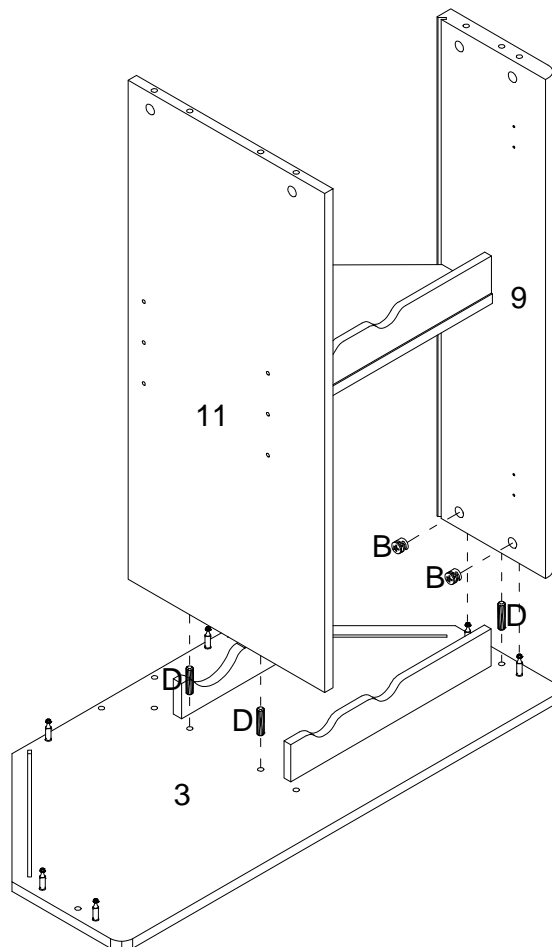

Step 11

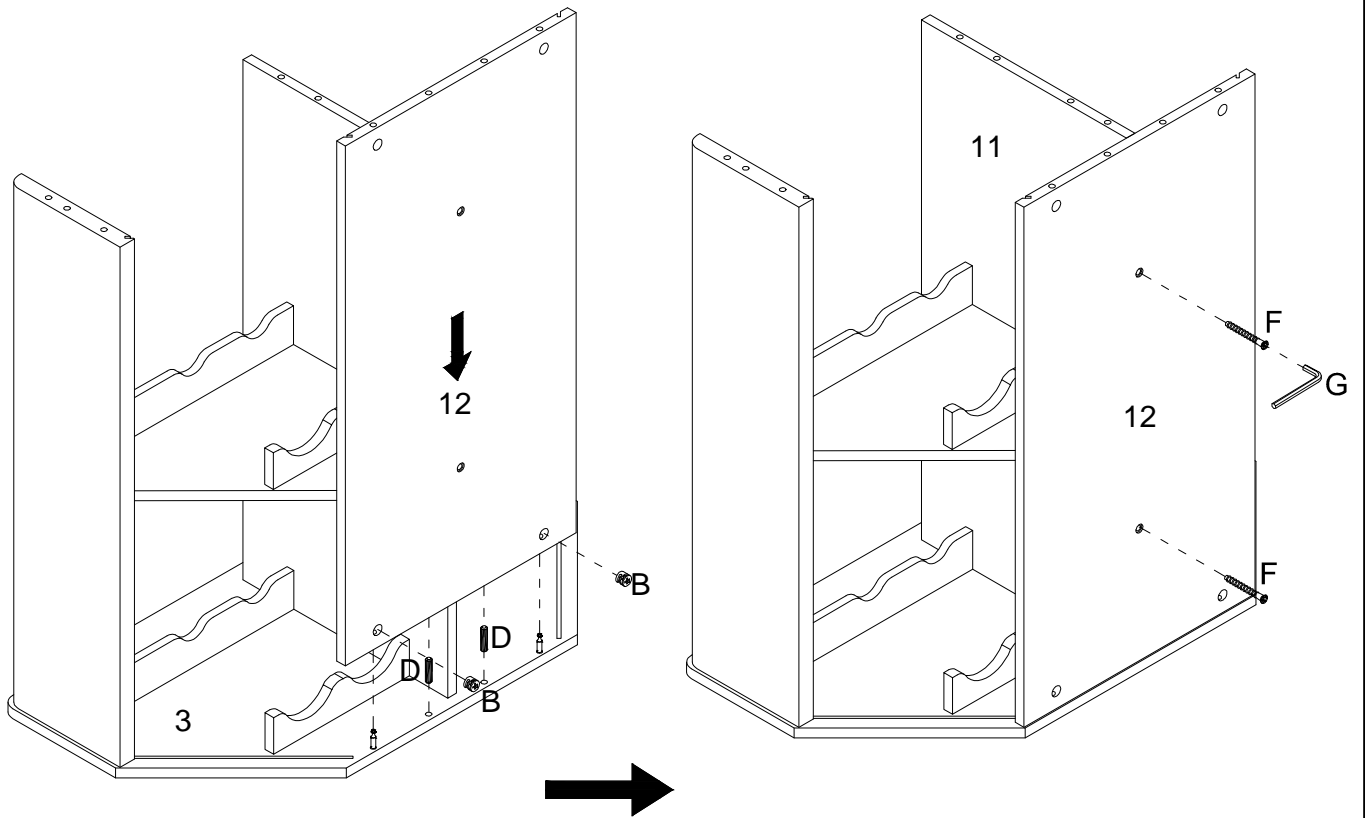

Step 12

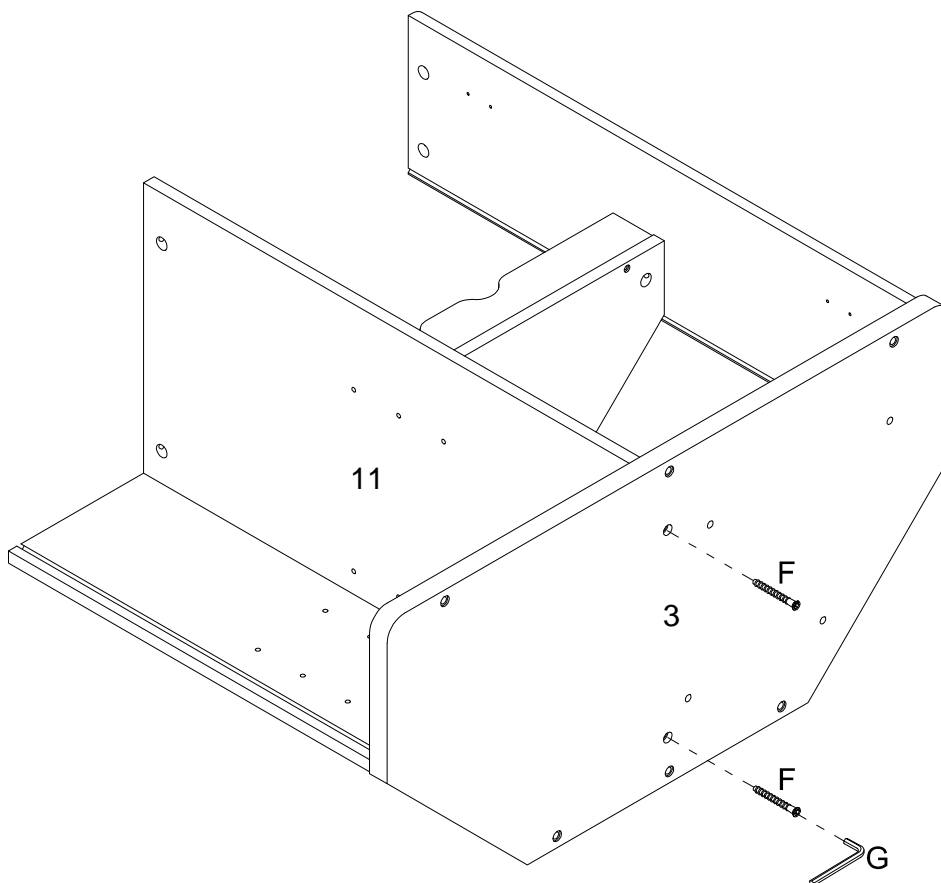

Step 13

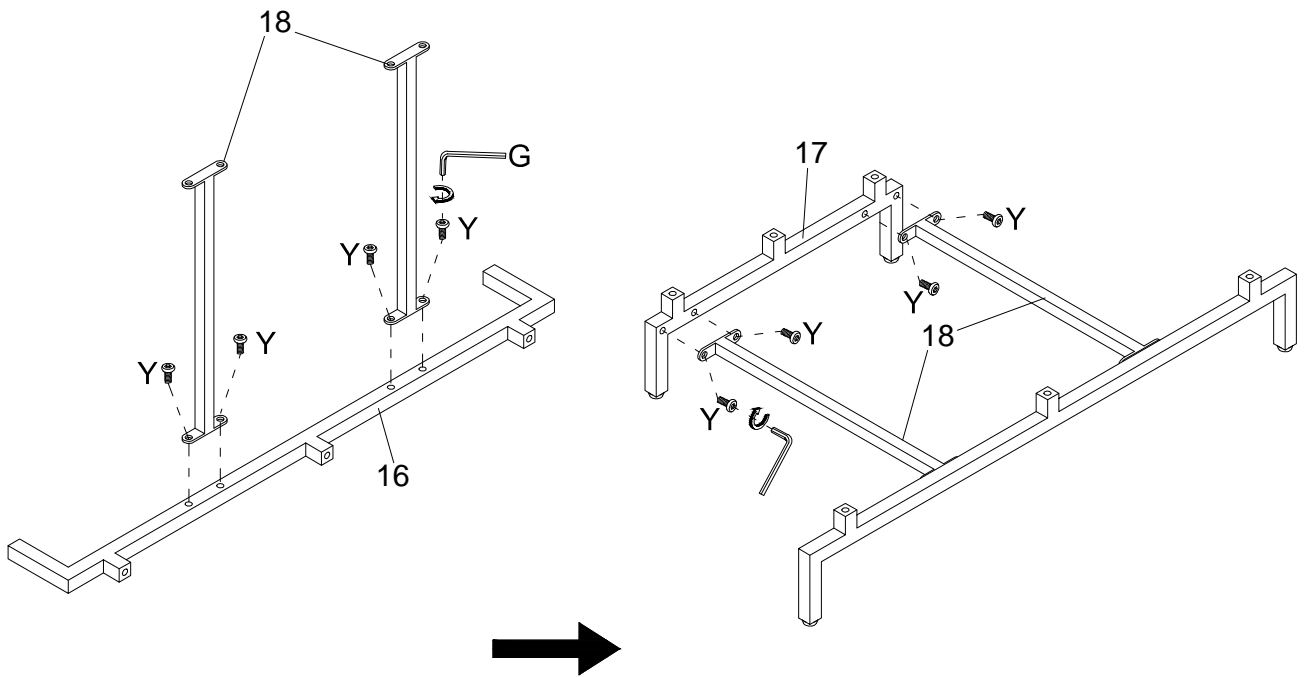

Step 14

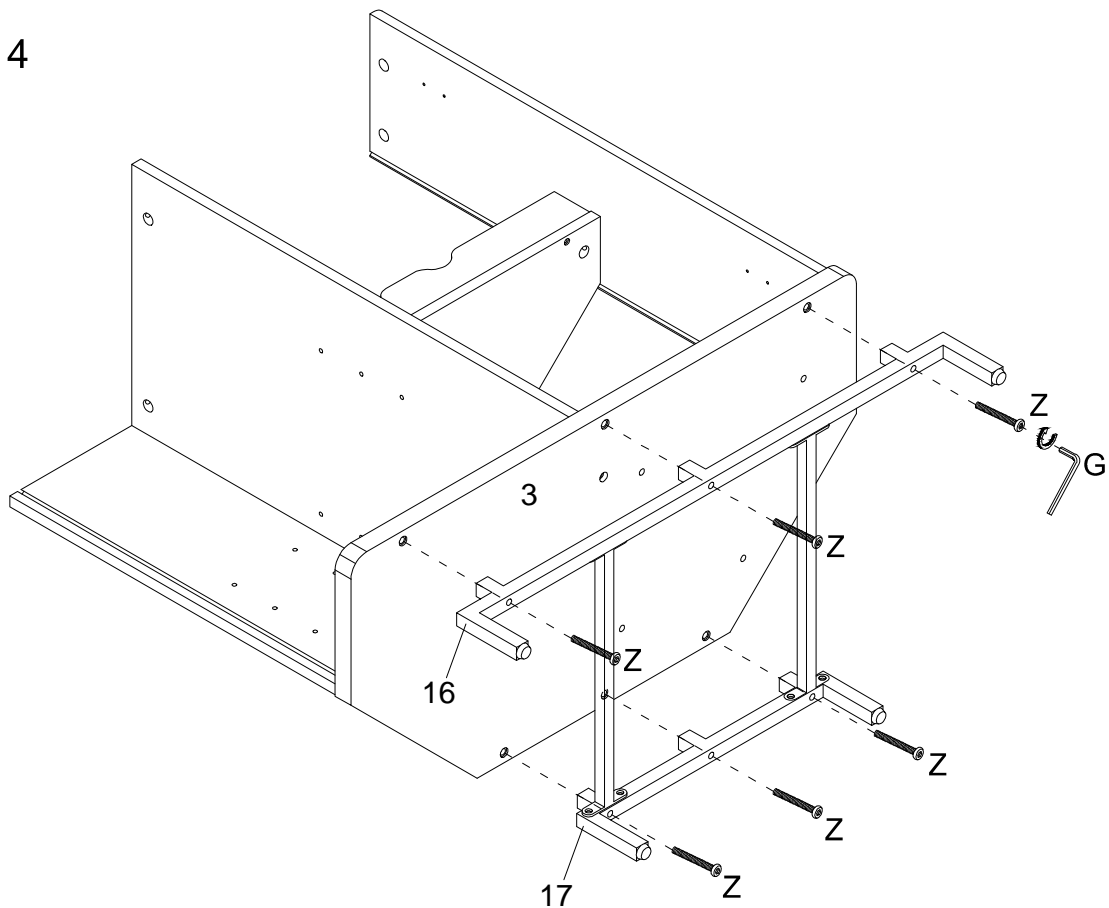

Step 15

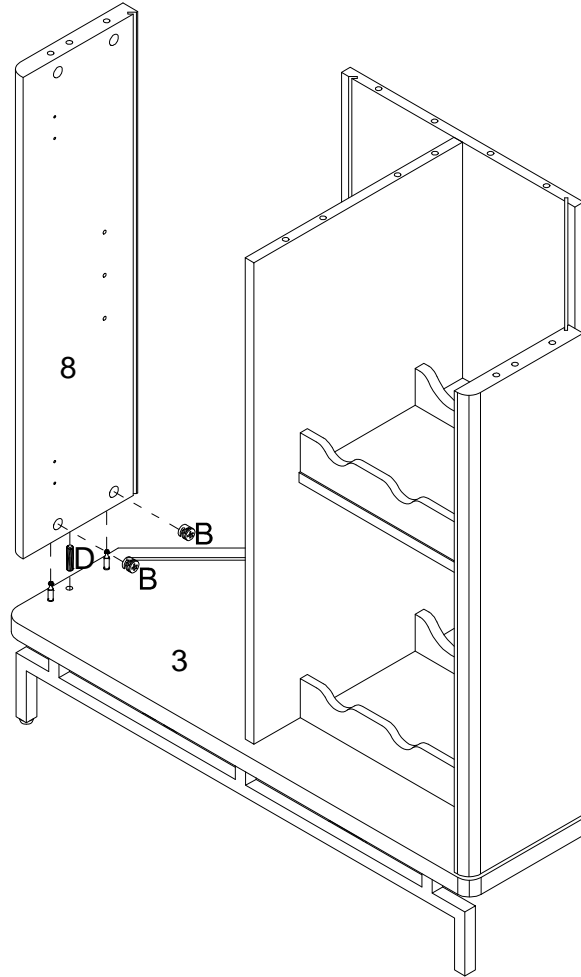

Step 16

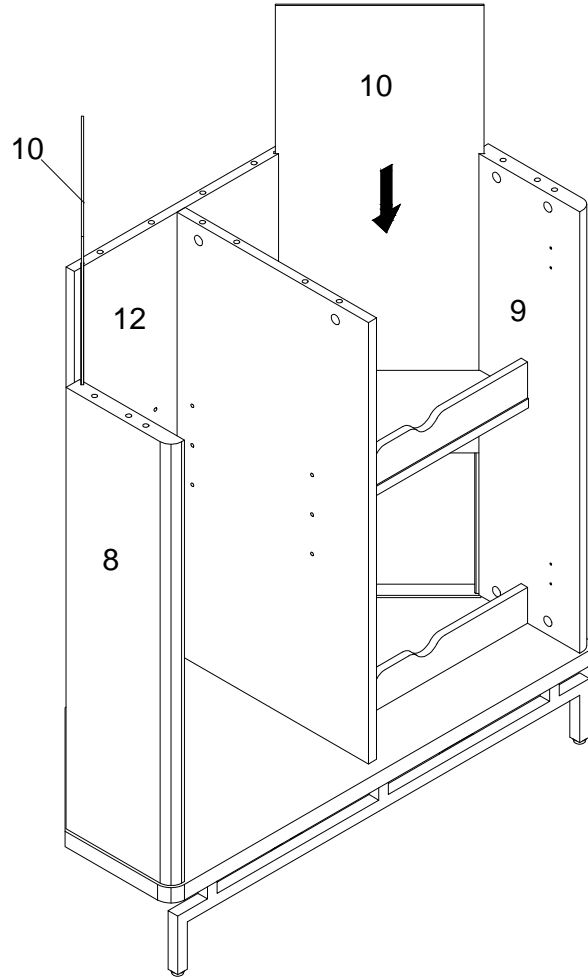

Step 17

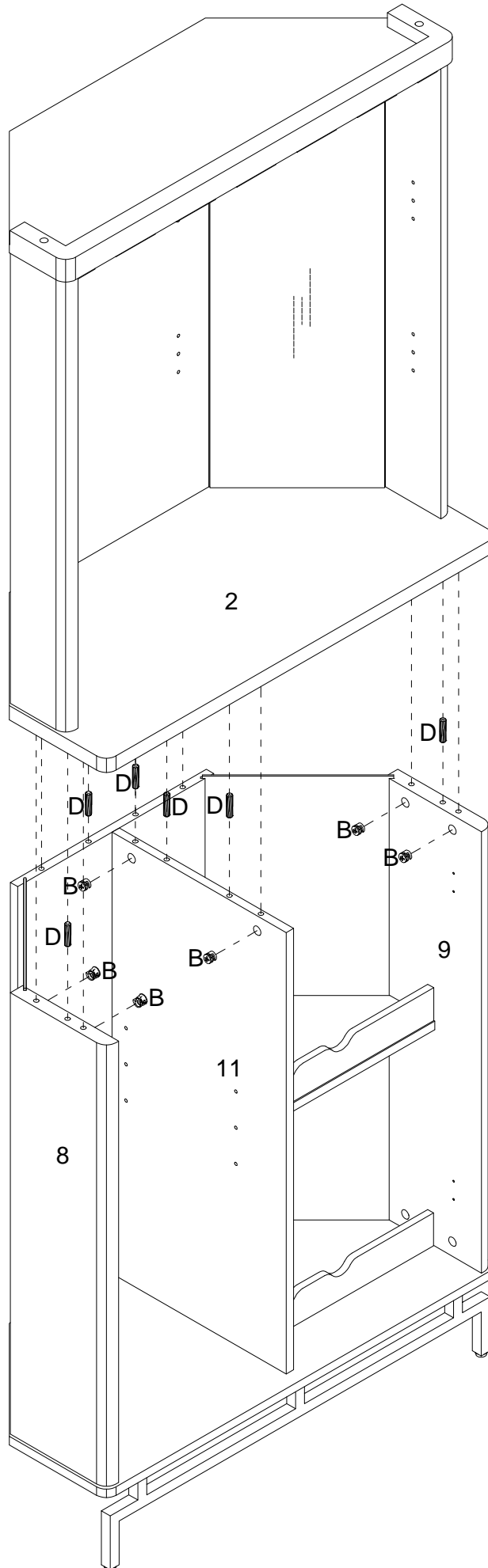
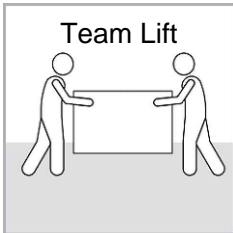

Step 18

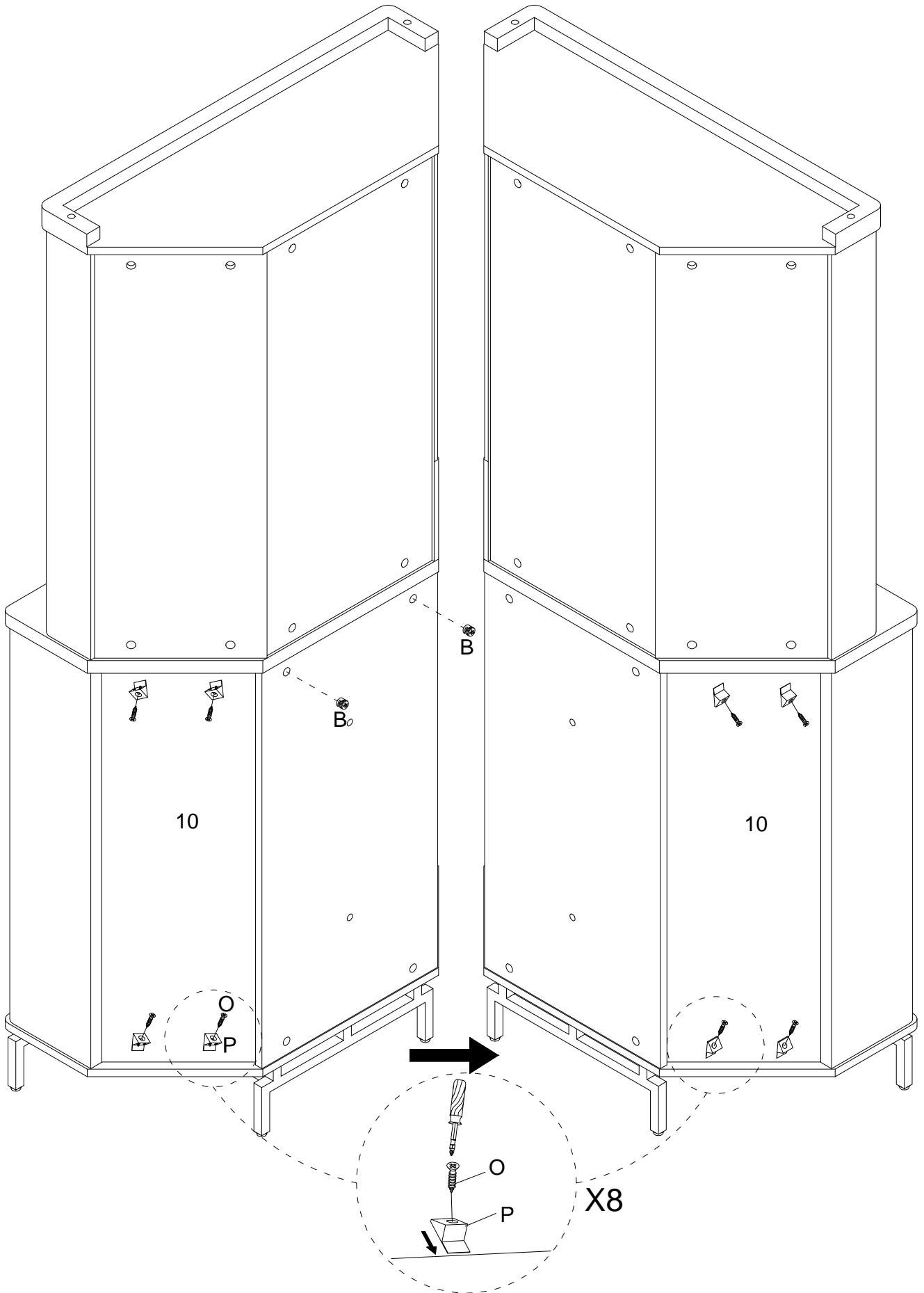

Step 19

Use glass shelf to match your style: one layer or two layers.

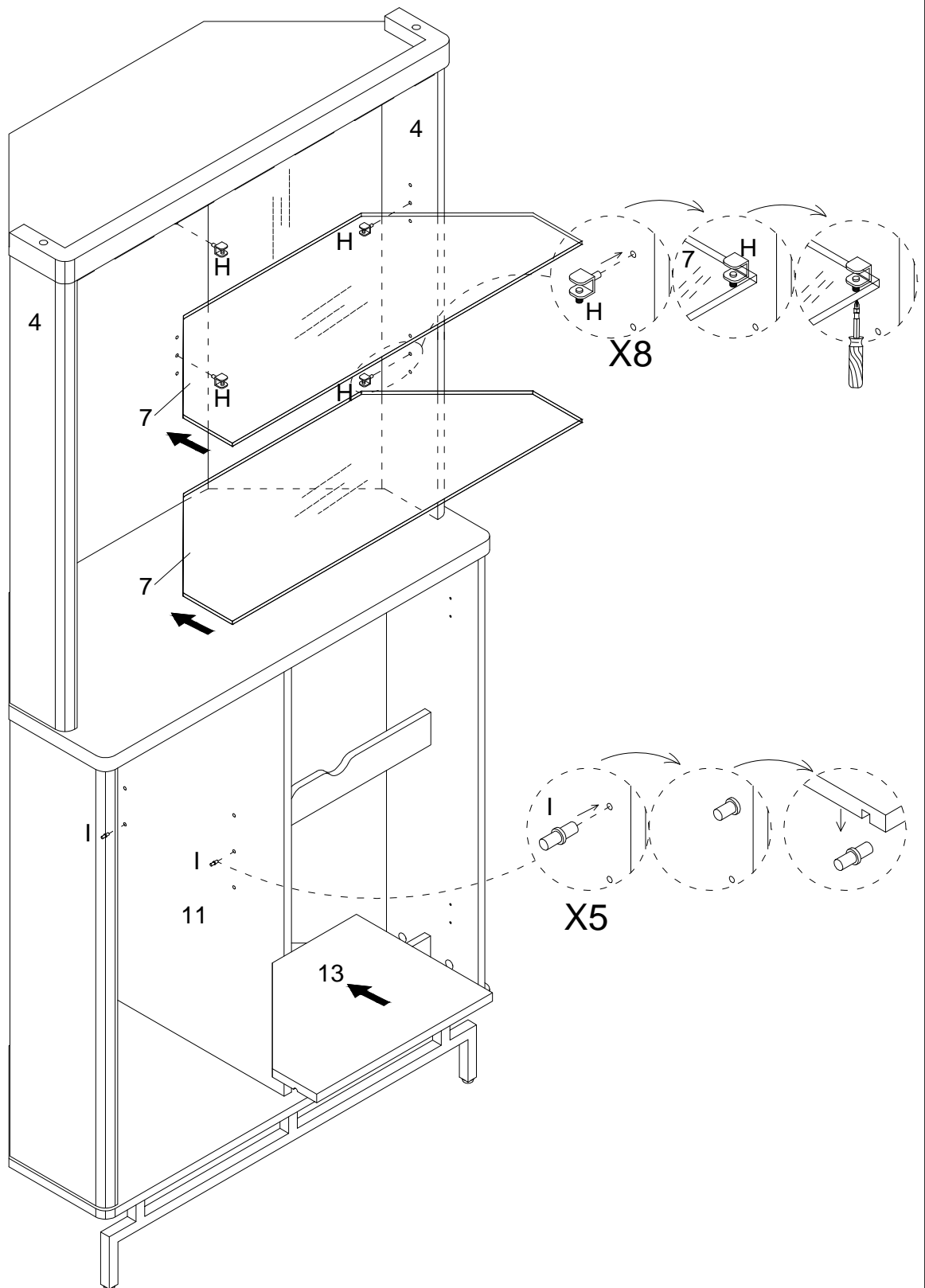

Step 20

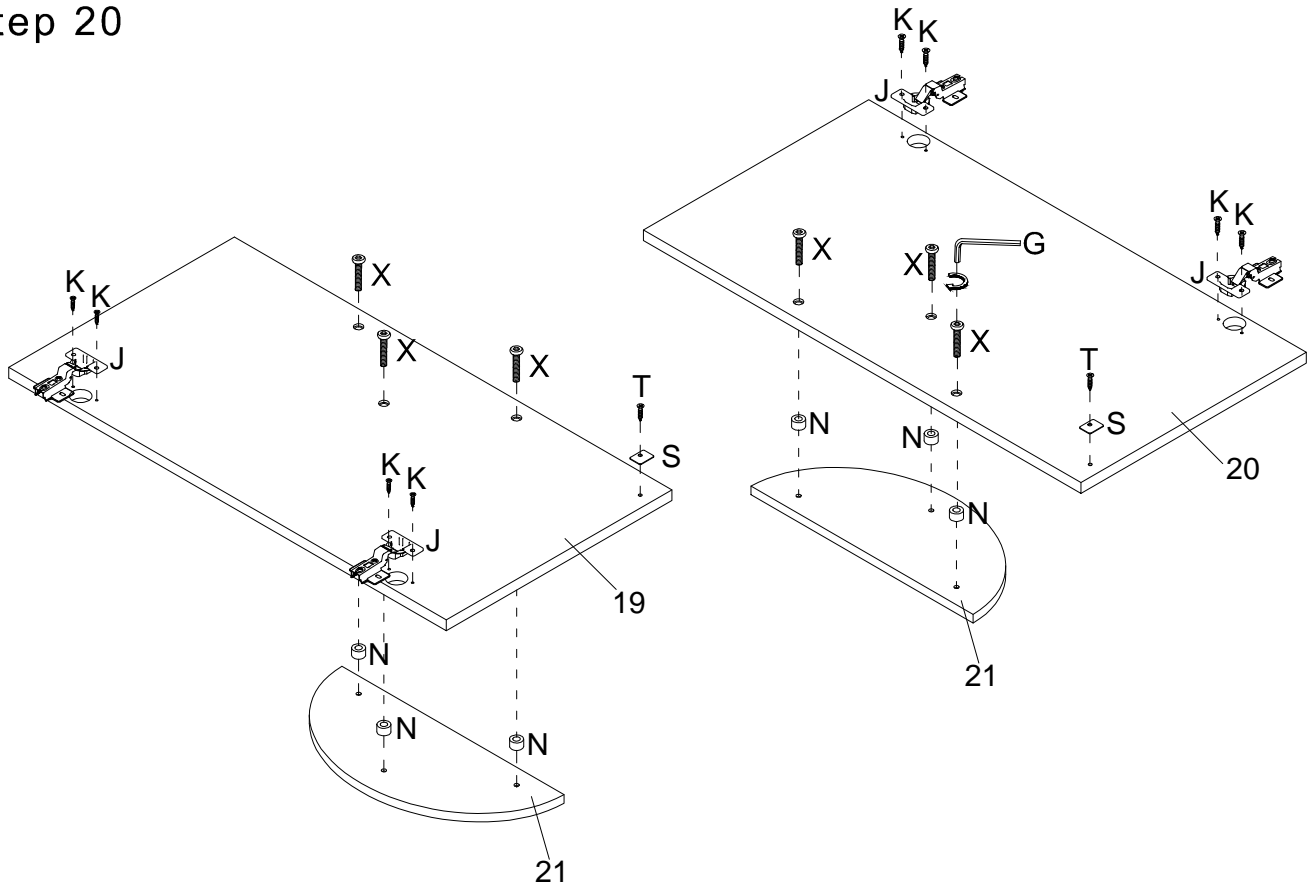

Step 21

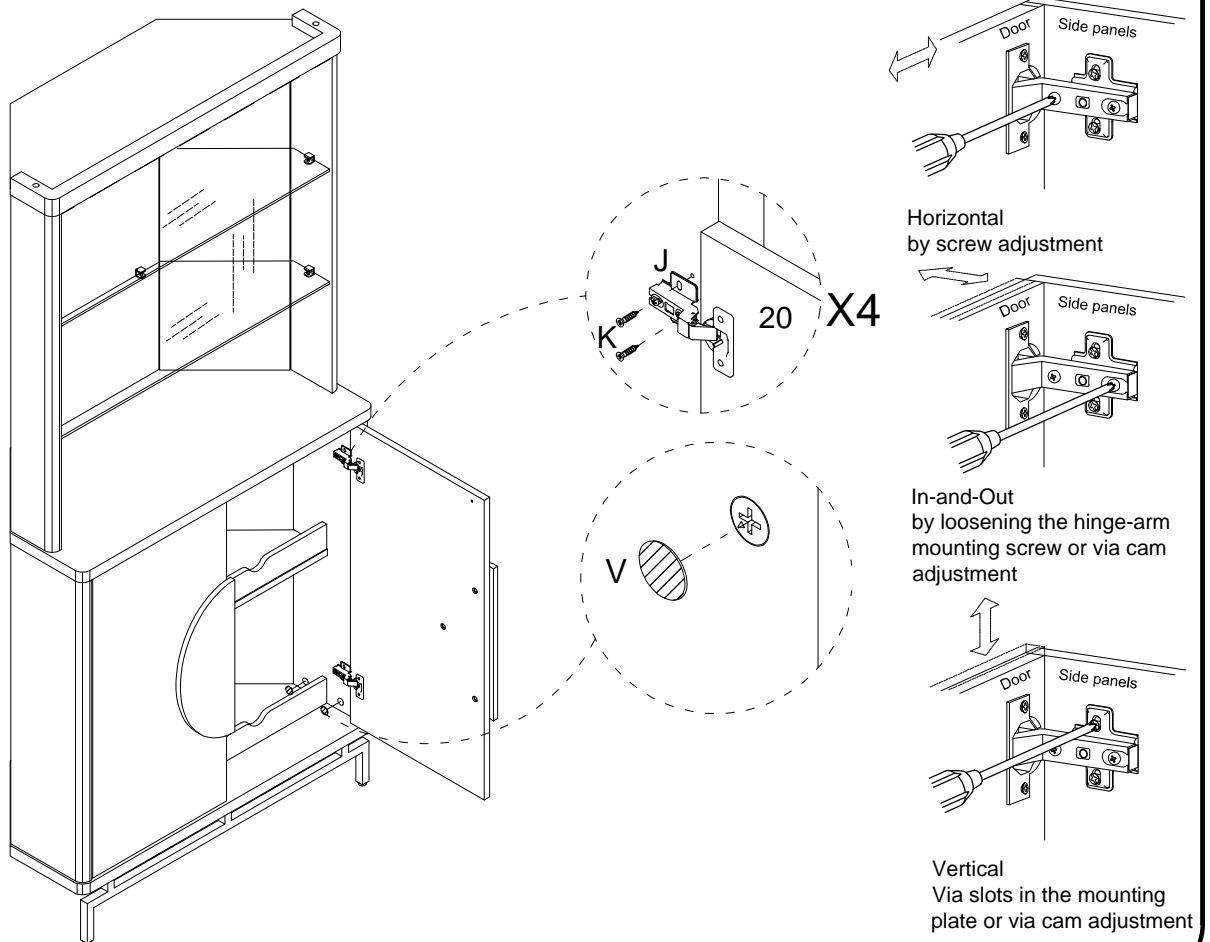

Step 22

